

Environmental Noise Study

Winchester Gateway Data Center- 2565-00642

INTRODUCTION

This report contains design information on environmental noise for the proposed Winchester Gateway Data Center in Frederick County, VA. This information is intended to assist Winchester Gateway LLC in meeting noise level requirements for the proposed construction set forth by Frederick County. This report does not address changes to construction that may be acoustically necessary to reduce excessive noise due to building mechanical or electrical services.

Executive Summary

Noise measurements were conducted at multiple locations surrounding the project site to document and characterize existing ambient sound levels. Results indicate a clear distinction between daytime and nighttime acoustic conditions.

Daytime noise along Apple Valley Road averaged 63–64 dB(A), dropping to about 47 dB(A) during the quietest nighttime period. Route 37 showed higher daytime levels of 67–68 dB(A), with the east side ranging 63–67 dB(A) due to nearby construction. Overall, Route 37 is 5–10 dB(A) louder than Apple Valley Road.

The frequency spectra exhibited elevated sound levels in the mid-frequency bands (500 Hz–2.5 kHz) and lower levels in the low-frequency range (50 Hz–500 Hz). Low-frequency noise presents greater mitigation challenges because attenuation at these frequencies typically requires materials with significant mass.

Overall, ambient sound levels remain steady throughout the day due to consistent traffic activity but drop during the late-night hours when traffic diminishes. With appropriate mitigation, the proposed data center operations may be minimally impactful, and possibly assist in masking disturbing short and impulsive noises caused by large trucks and sirens.

A representative model of the proposed data centers was created using SoundPlan environmental modeling software and assuming both the county specified protections (low sound fan options, mufflers, generator enclosures, etc.) and a parapet that is at least 9' 6" above the roof level to fully block line of sight to the roof top equipment.

Normal operations are expected to produce noise levels of less than 65 dB(A) during daytime hours and 60 dB(A) during nighttime hours. While these nighttime levels exceed the ambient noise levels during the quietest hours, because they are steady state they will serve to mask disturbing impulsive and short spikes in noise levels caused by large trucks and emergency vehicles.



MEASUREMENTS

Location

Site is located on the southeast corner of Apple Valley Rd and Middle Rd in Winchester, VA 22602



Spot measurements were taken at the following times and locations:

10/22 **Afternoon** 11:47 a.m. – 2:33 p.m.: Full perimeter

10/23 **Late-night** (early morning) 3:46 a.m. – 4:26 a.m.: Along Apple Valley Rd

10/23 **Morning** 7:44 a.m.- 8:47 a.m.: Full perimeter

10/23 **Evening** 5:11 p.m. – 5:34 p.m.: Along Apple Valley Rd

10/23 **Night** 8:59 p.m. – 9:26 p.m.: Along Apple Valley Rd

A graphic showing the approximate spot check locations is included in Appendix C.

Due to safety concerns after dark, nighttime spot checks around the full perimeter were not conducted but were limited to Apple Valley Road. Apple Valley Road was prioritized because of its proximity to residential areas.



Observations

Traffic along Apple Valley Road was steady and consistent from early morning through the evening hours, contributing to stable daytime noise levels. During the late-night/early-morning periods, traffic activity decreased, resulting in lower ambient sound levels.

Active construction activity was observed on the east side of the site, characterized by frequent and pronounced hammering sounds that contributed intermittently to elevated noise levels in that area.

The surrounding land use consists primarily of single-family residences along the north side of Apple Valley Road, adjacent to the project property line. Beyond these residential areas, the surrounding environment is predominantly agricultural and industrial.

Results

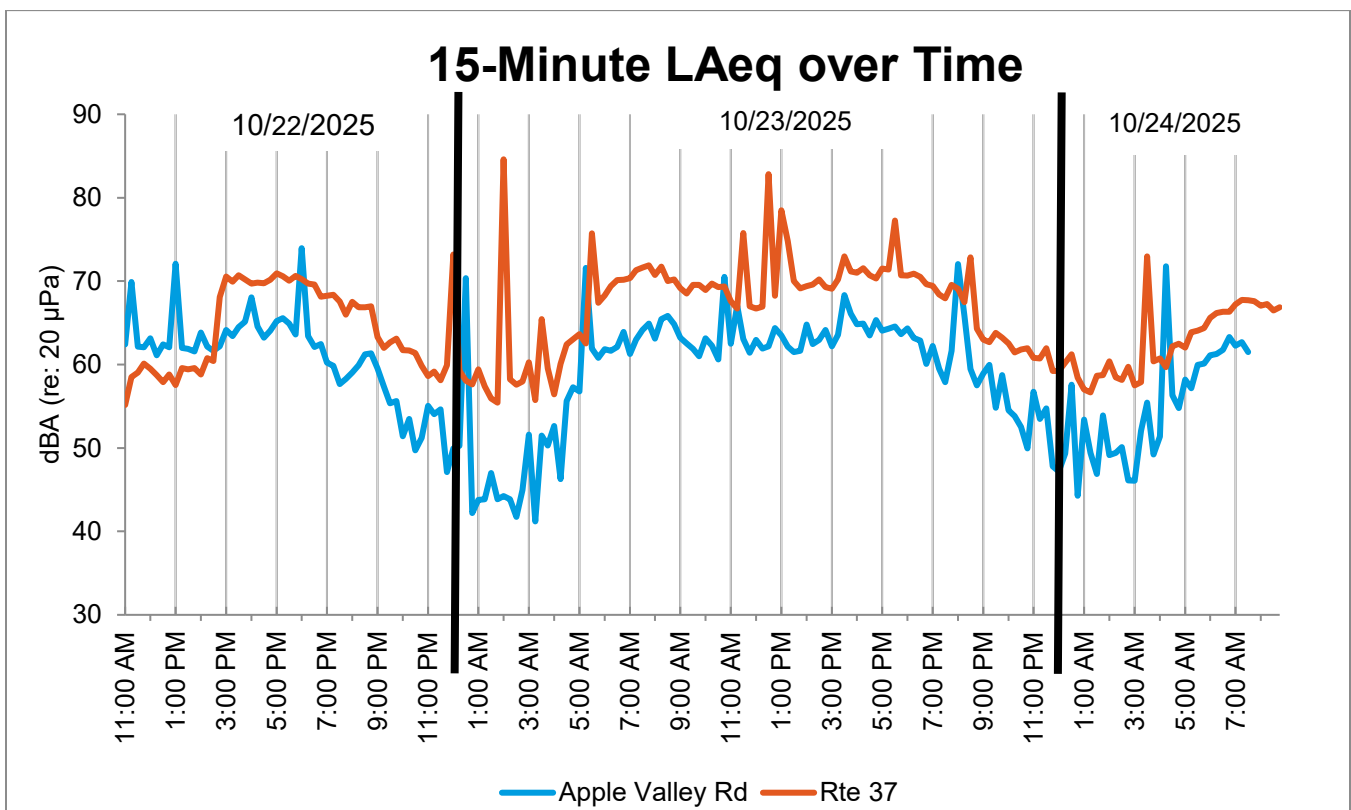

Noise levels during daytime hours remained steady, decreasing between approximately 9:00 p.m. and 5:00 a.m. Several isolated spikes were observed during the late-night period, though these were not directly witnessed in the field. Such events may have resulted from emergency vehicle activity, passing heavy trucks operating overnight, or nearby wildlife.

Overall, sound levels along Route 37 were 5–10 dB(A) higher than those measured along Apple Valley Road.



While the average sound level decreased noticeably between the hours of 11pm and 4am on both nights, periodic noises from ambulances, motorcycles and other vehicles along Route 37 did not change. This results in short-term noise events which rise over the noise floor by 40-60 dB(A).

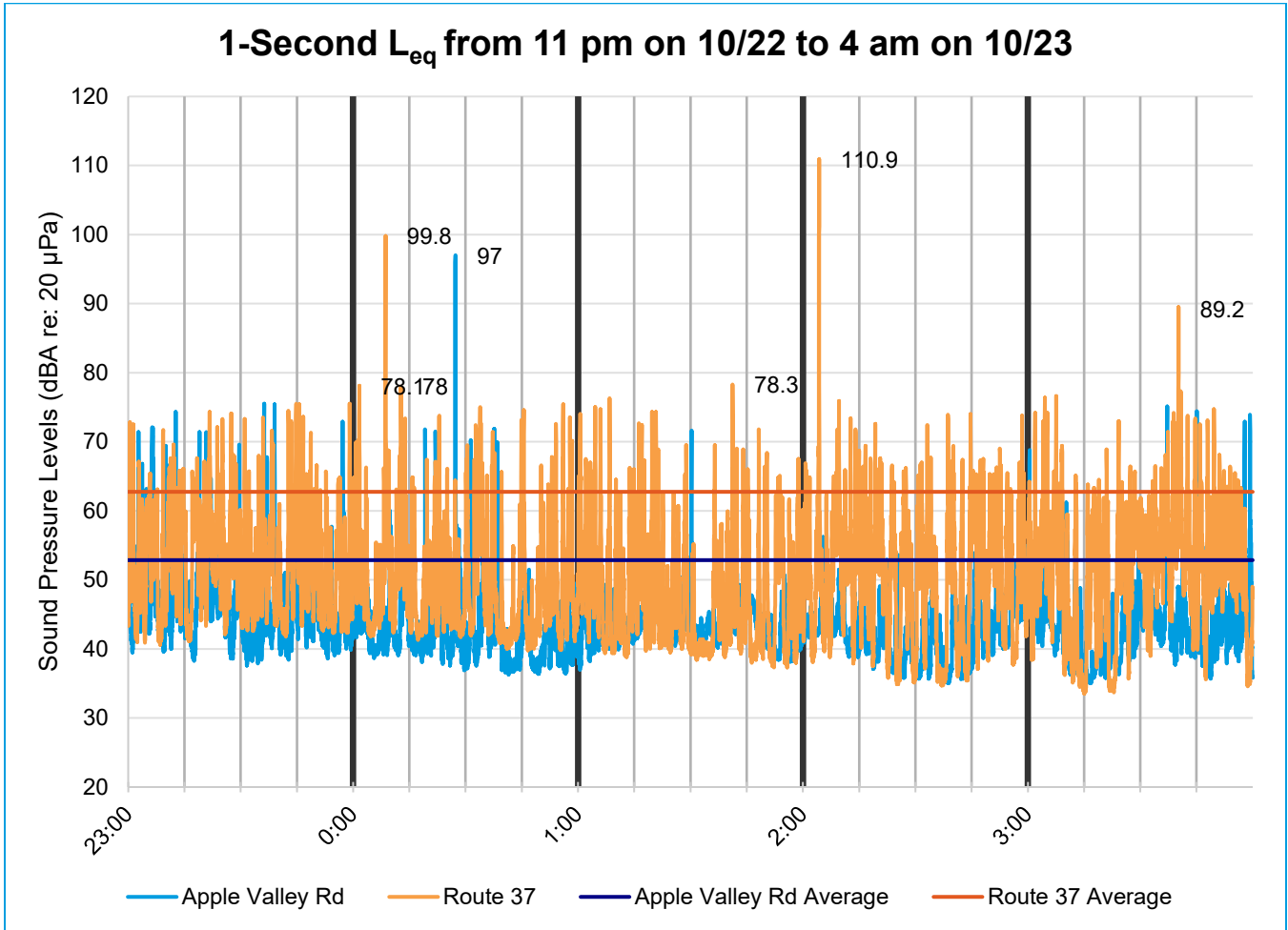

The full set of Logged 1 second L_{eq} data is included in Appendix D for reference.



Noise Levels along Apple Valley Rd.

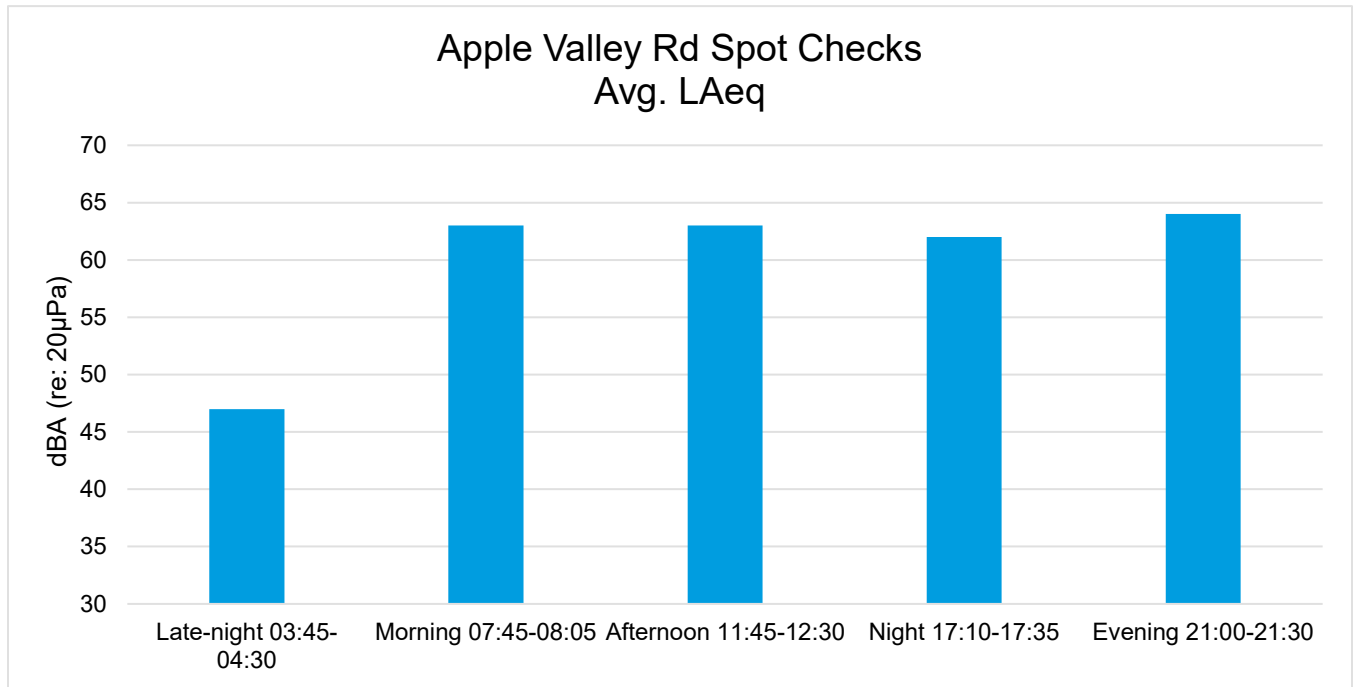

Five short-term measurements were taken along the length of plot bordering Apple Valley Road and averaged for each time frame. Daytime noise levels were consistent, ranging from 62 to 64 dB(A), while nighttime levels were approximately 15 dB(A) lower.

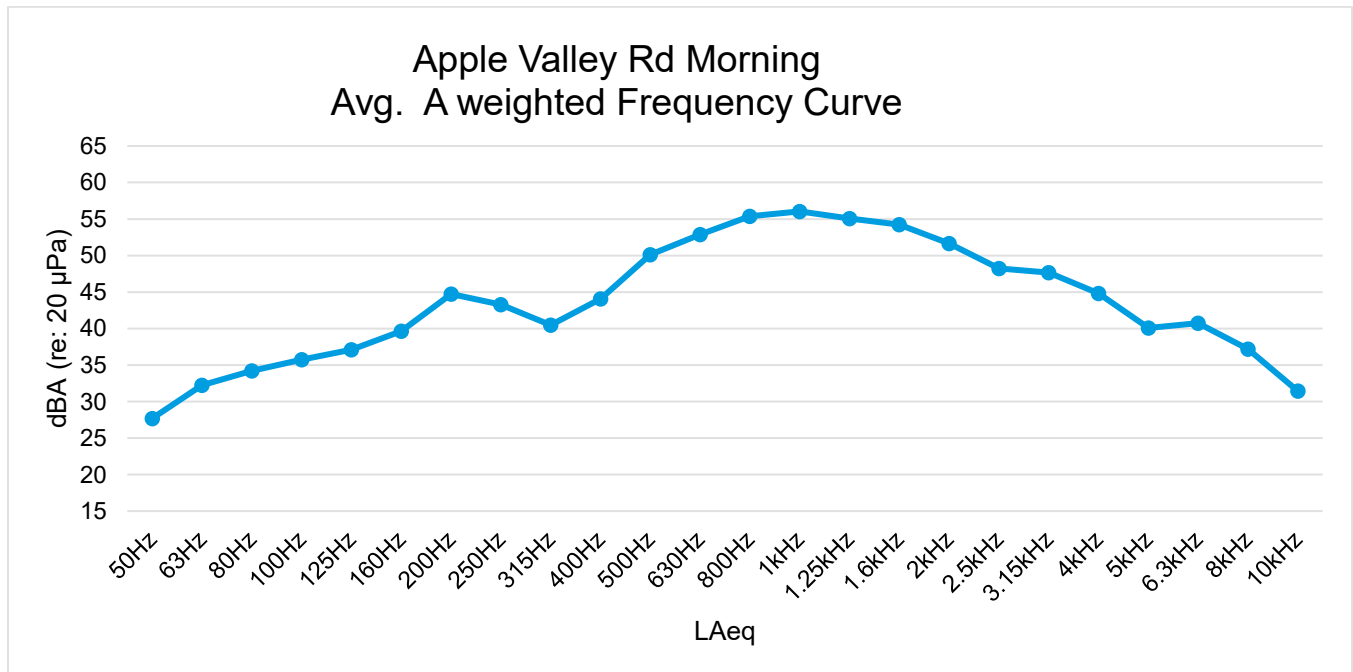

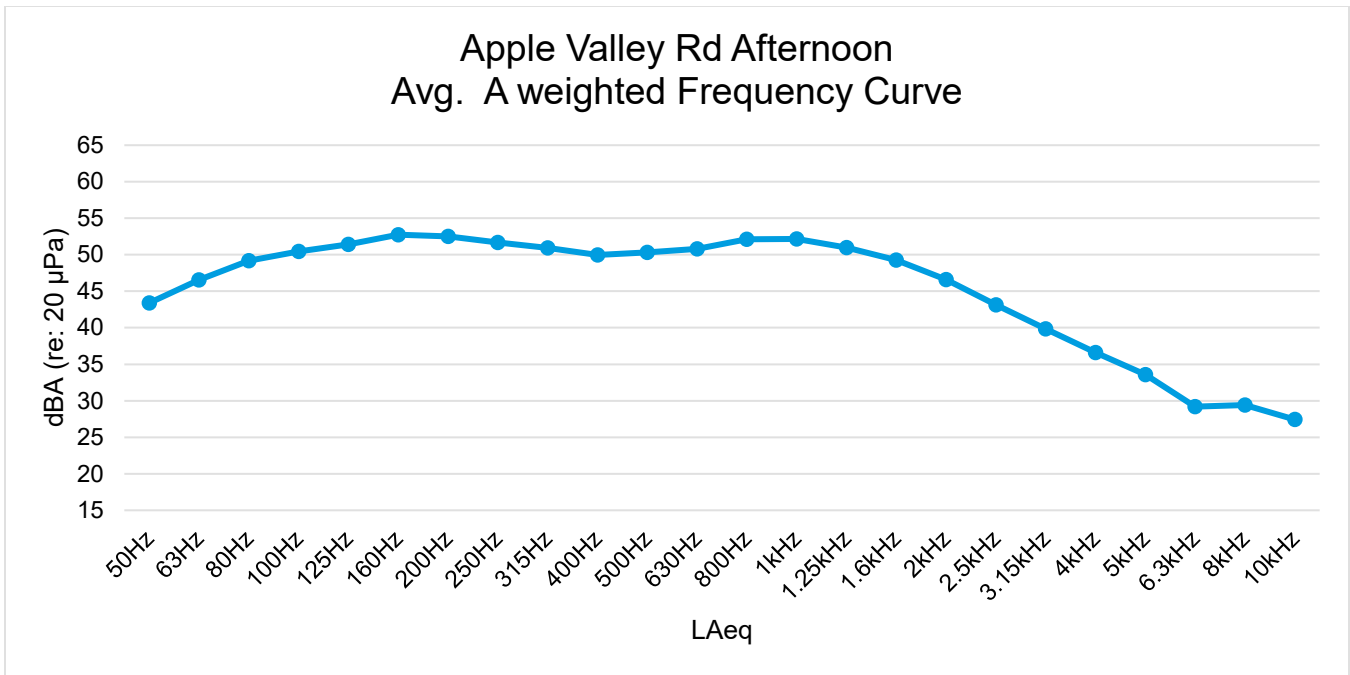

The frequency spectra were also consistent across the spot measurements. Only the afternoon measurement exhibited a noticeably different spectral profile, likely due to construction activity on the east side that was active during that period. It is noteworthy that low-frequency components (50 Hz–500 Hz) were lower in level than the mid-frequency range (500 Hz–2.5 kHz).

Noise Levels along Route 37

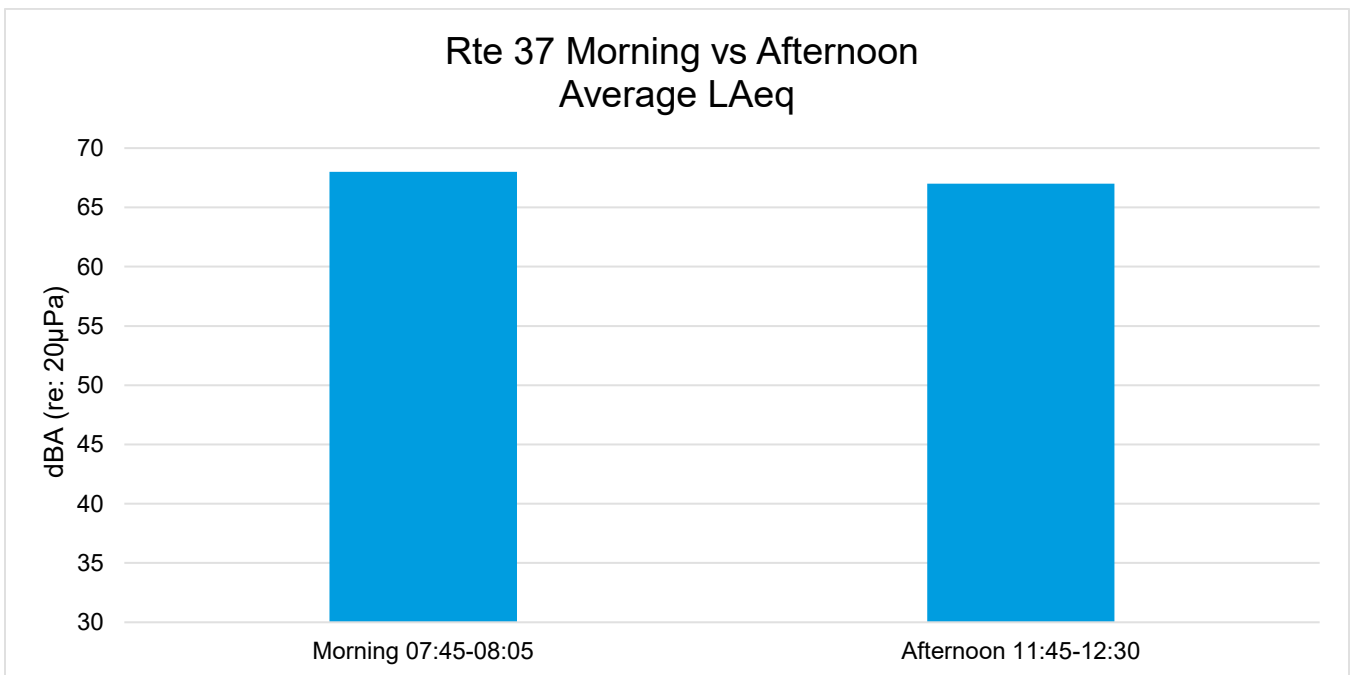

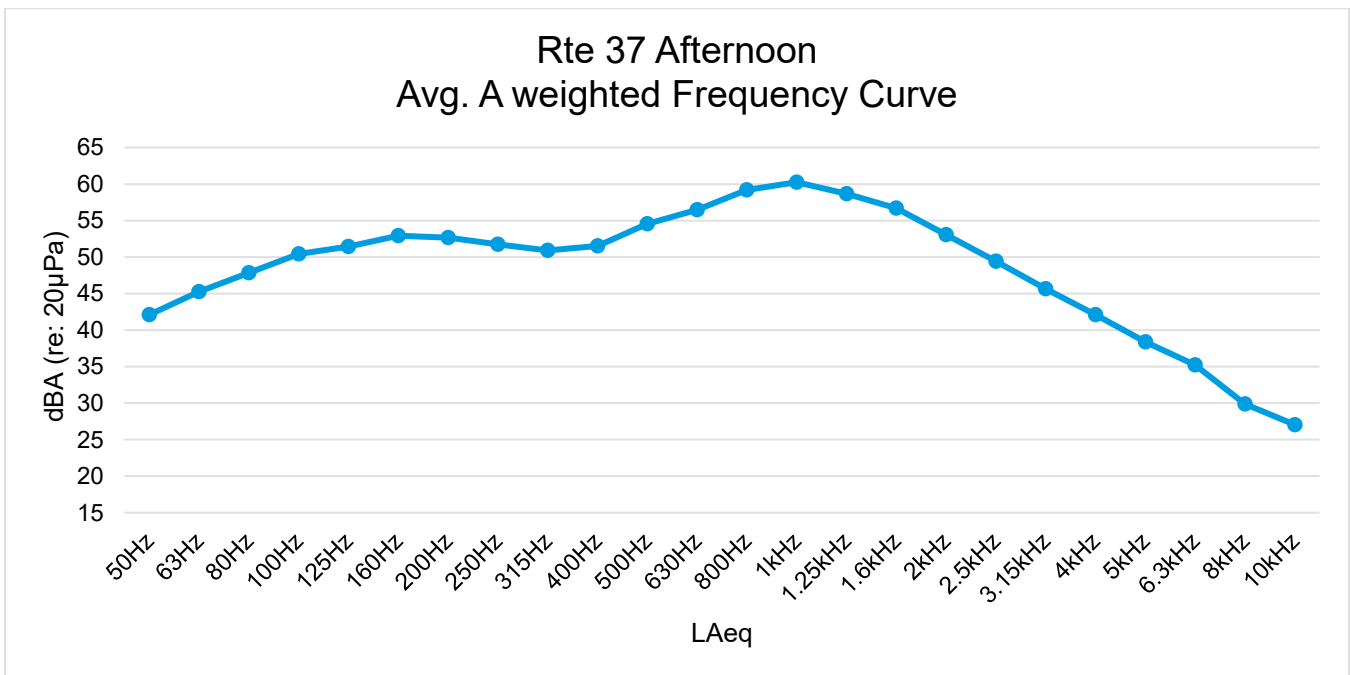
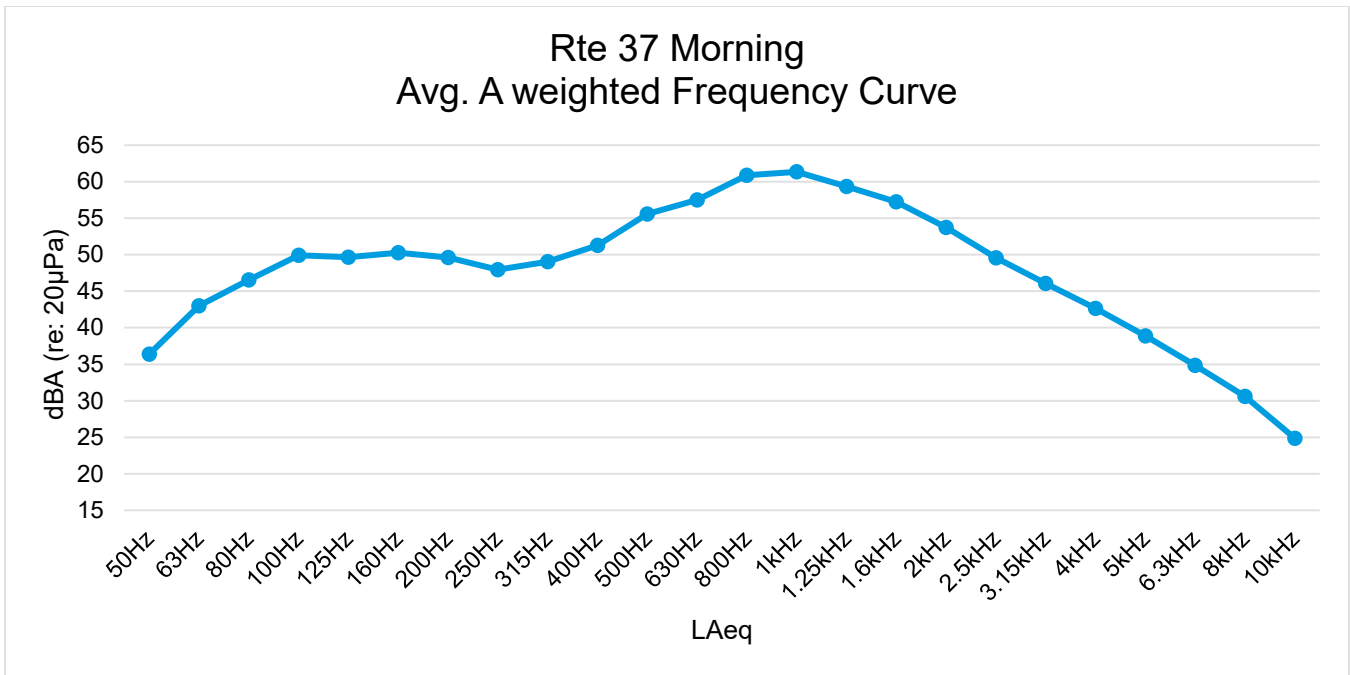

The frequency spectra along Route 37 were consistent across the morning and afternoon spot measurements. While low-frequency levels were also lower along this corridor, the difference was less pronounced than on Apple Valley Road. This is likely due to the higher volume of heavy-trailer traffic on the highway, which contributes additional low-frequency energy.



Noise Levels along East Side

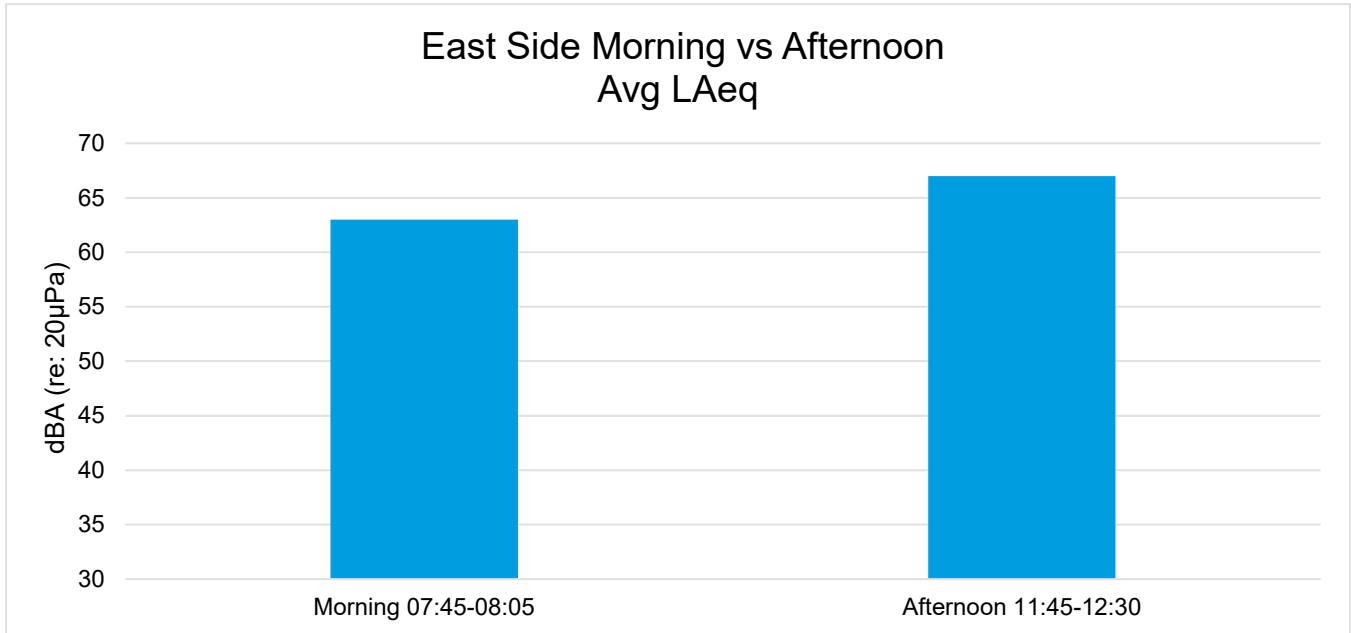

The differences in levels between the morning and afternoon spot checks is more pronounced. It was observed in other measurements as well that the increased construction noise coming from the east side added to the low frequency content of the afternoon measurements. The morning measurements are more likely to be indicative of the normal sound levels in the area.

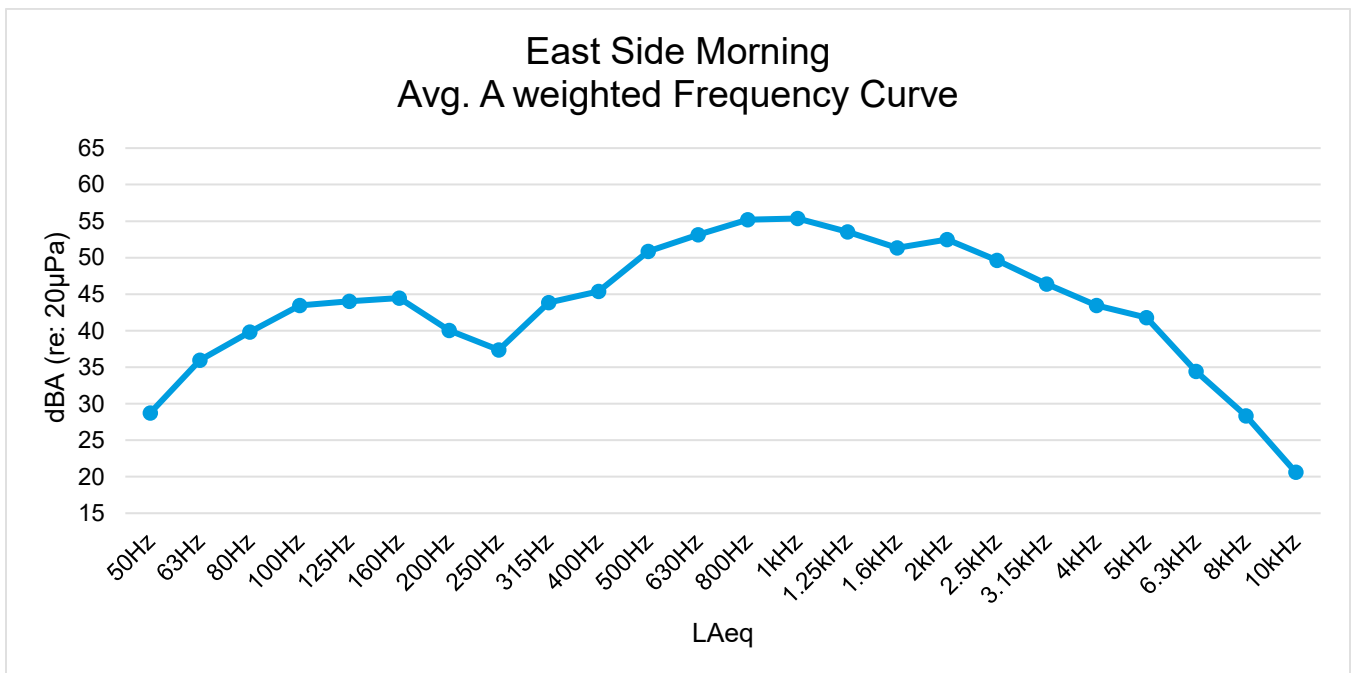

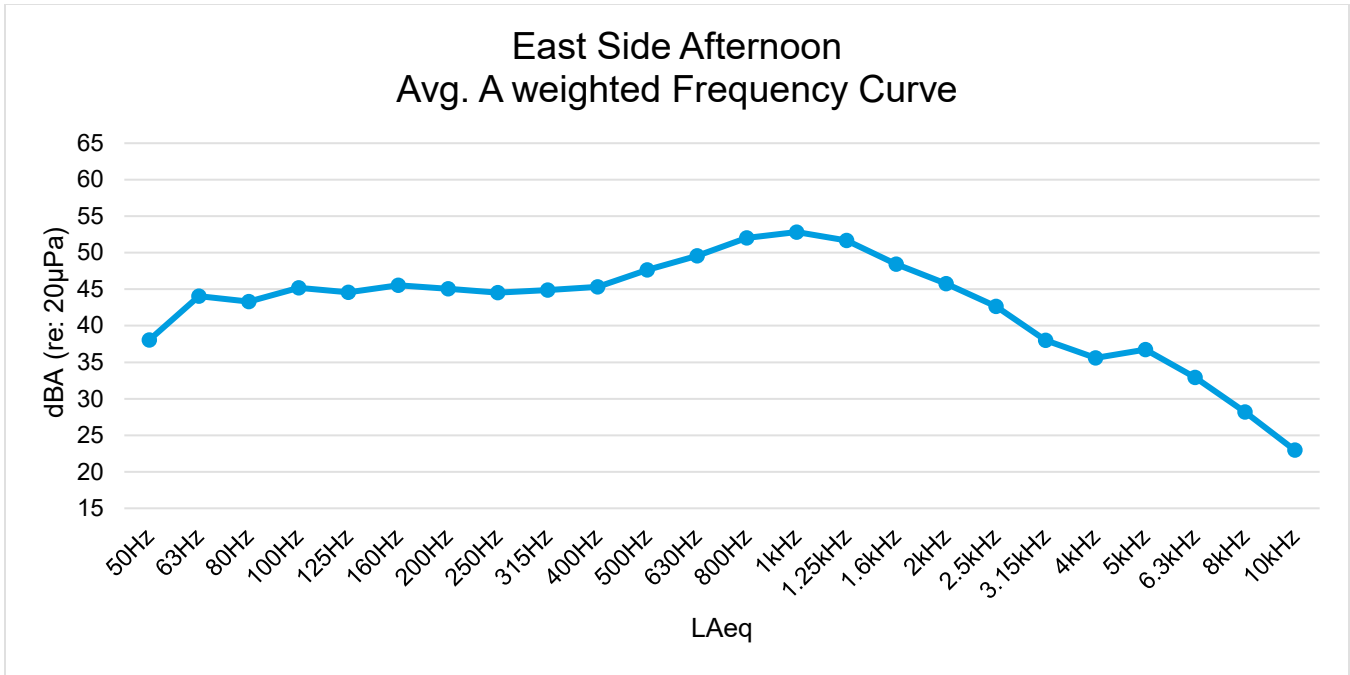

ANALYSIS

SoundPLAN Model

Salas O'Brien constructed an environmental noise model to assist in predicting the noise impact to the surrounding areas. We used both rooftop and generator equipment typical of a data center of the proposed size.

Equipment and dB values:

The sound power levels that were used in the model for each piece of equipment is listed in the table below. All data in the table is shown in dB re: 10^{-12} W.

	63Hz	125Hz	250Hz	500Hz	1kHz	2kHz	4kHz	8kHz
Greenheck Exhaust Fan	78	77	84	74	67	66	62	59
Cook 36 LXUL	89	91	89	84	80	75	70	66
RTU-A Inlet	83	81	84	81	75	73	71	65
RTU-A Outlet	83	81	84	81	75	73	71	65
CRAC Condenser	84	94	95	93	88	85	82	78
Cook 48 LXUL	94	96	92	88	84	79	75	70
AHU Condensing Unit	62	74	83	88	88	85	81	75
House Generator	81	83	90	82	81	77	70	70
Generator KD3000	92	115	115	117	118	117	113	108

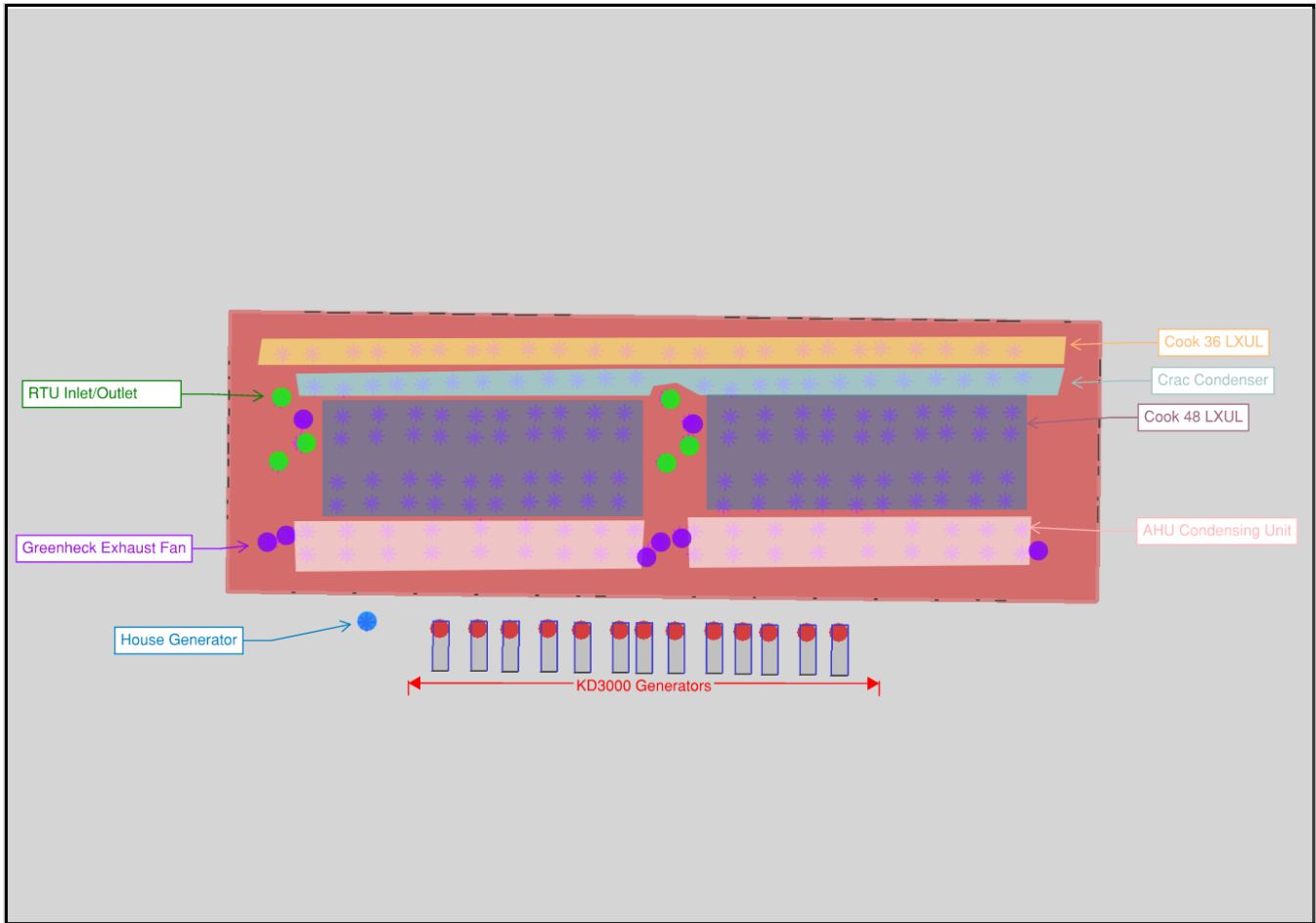

Simulations

3 simulations were ran in total, with results shown both in dB(A) (dB(A) is a frequency weighting standard that approximates human hearing at normal listening levels) as described below:

1. Normal Operating conditions. All rooftop equipment running.
2. Test conditions. All rooftop equipment running plus 1 emergency generator nearest property line
3. Emergency conditions. All rooftop equipment and generators running.



Highest dB(A) predicted at property line:

	Normal Operations	Test Conditions	Emergency Conditions
North	55	56	59
Northwest	47	47	50
Southwest	54	54	56
South	51	51	53
East	53	53	53

RECOMMENDATIONS

In addition to the requirement set by the county to install all equipment with the low sound fan options, mufflers on exhaust stacks, and generators within the sound rated enclosures, we recommend implementing a parapet that is at least 9' 6" above the roof level to fully block line of sight to the roof top equipment and help mitigate the sound level from such.

With this, and equipment that does not exceed the modeled levels, we anticipate that the data center during normal operating conditions would be noticeably quieter than the industrial limits that are currently placed on the site. With the proper selection of generator enclosures, this data center should also be able to not exceed the industrial limits even during an emergency condition where all generators are operating.

Contributors:

ALEX HORNECKER, INCE Bd. Cert.
Senior Consultant, Acoustics
D 469.726.4275
E alex.hornecker@salasobrien.com

Aaron Walker
Acoustic Designer
D 303.472.0779
E aaron.walker@salasobrien.com



APPENDIX A - DEFINITIONS

A-weighted Sound Level (dB(A))

A unit of sound level that measures how loud a sound is perceived by the human ear. It is a weighted measurement that adjusts the raw decibel reading to account for the fact that human hearing is less sensitive to very low and very high frequencies than it is to mid-range frequencies.

C-weighted Sound Level (dB(C))

A unit of sound level that measures how loud a sound is perceived by the human ear at higher sound levels, where hearing is relatively flatter across frequencies. It applies a gentler weighting than A-weighting, reducing the correction of low and high frequencies and providing a measurement that better represents loud or bass-rich sounds.

Leq

The equivalent continuous sound level is the sound level in decibels, having the same total sound energy as the fluctuating level measured. Leq is also known as the time-average sound level (LAT).

LAeq

The A-weighted, equivalent continuous sound level, in decibels having the same total sound energy as the fluctuating level measured.

Frequency Spectrum

A representation of sound energy distribution as a function of frequency, typically displayed in one-third-octave bands.

Sound Power

The total acoustic energy emitted by a source per unit time, expressed in watts. It is an inherent property of the source and does not depend on distance or environment.

Sound Pressure

The local variation in atmospheric pressure caused by a sound wave, measured in pascals (Pa). It represents the force of the sound on a surface area and is what the human ear perceives as loudness.

APPENDIX B- SITE PLAN

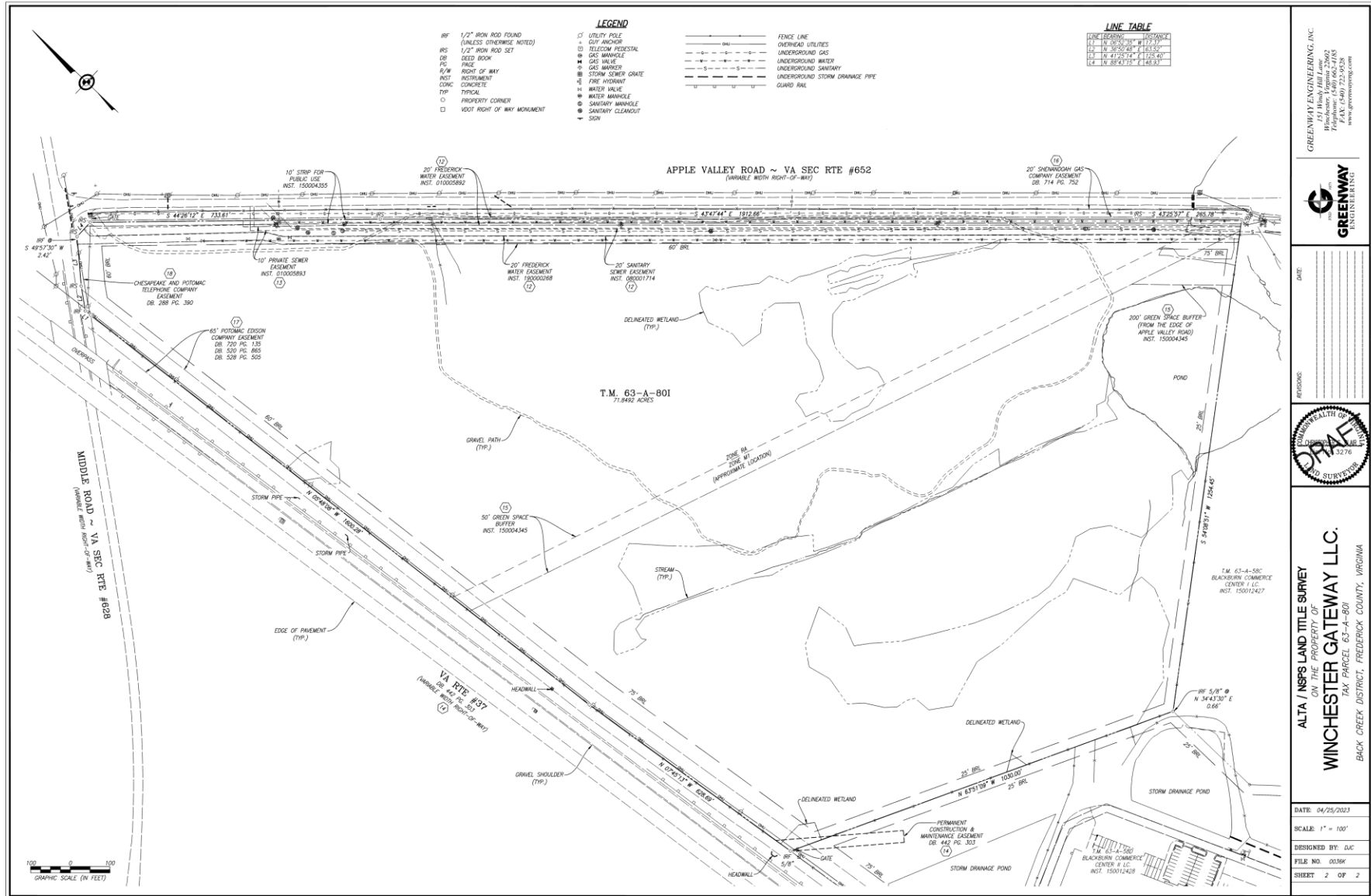



APPENDIX C- MEASUREMENT LOCATIONS



APPENDIX D

10.22.2025 Logged Data – 1 second L_{eq}

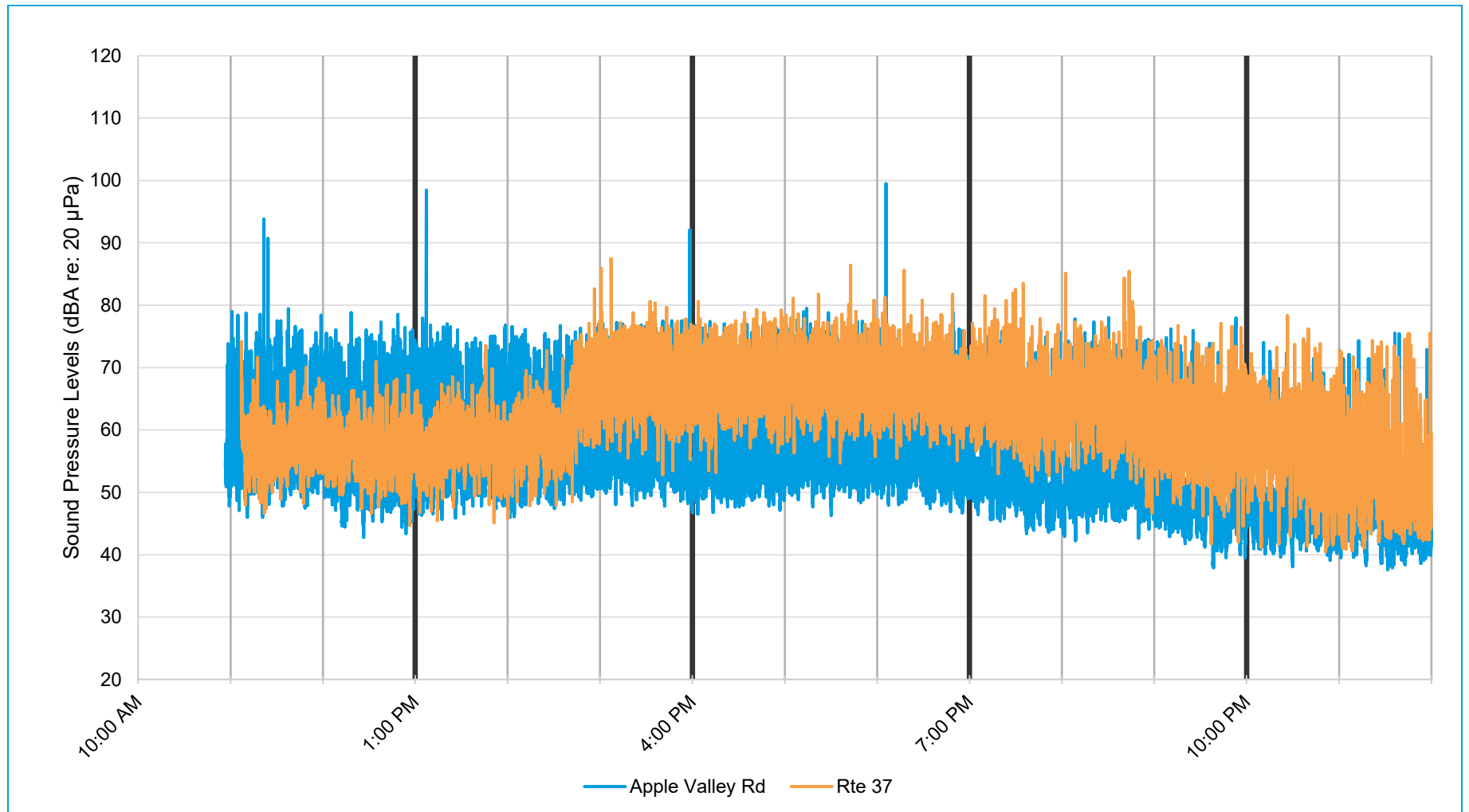



10.23.2025 Logged Data – 1 second L_{eq}

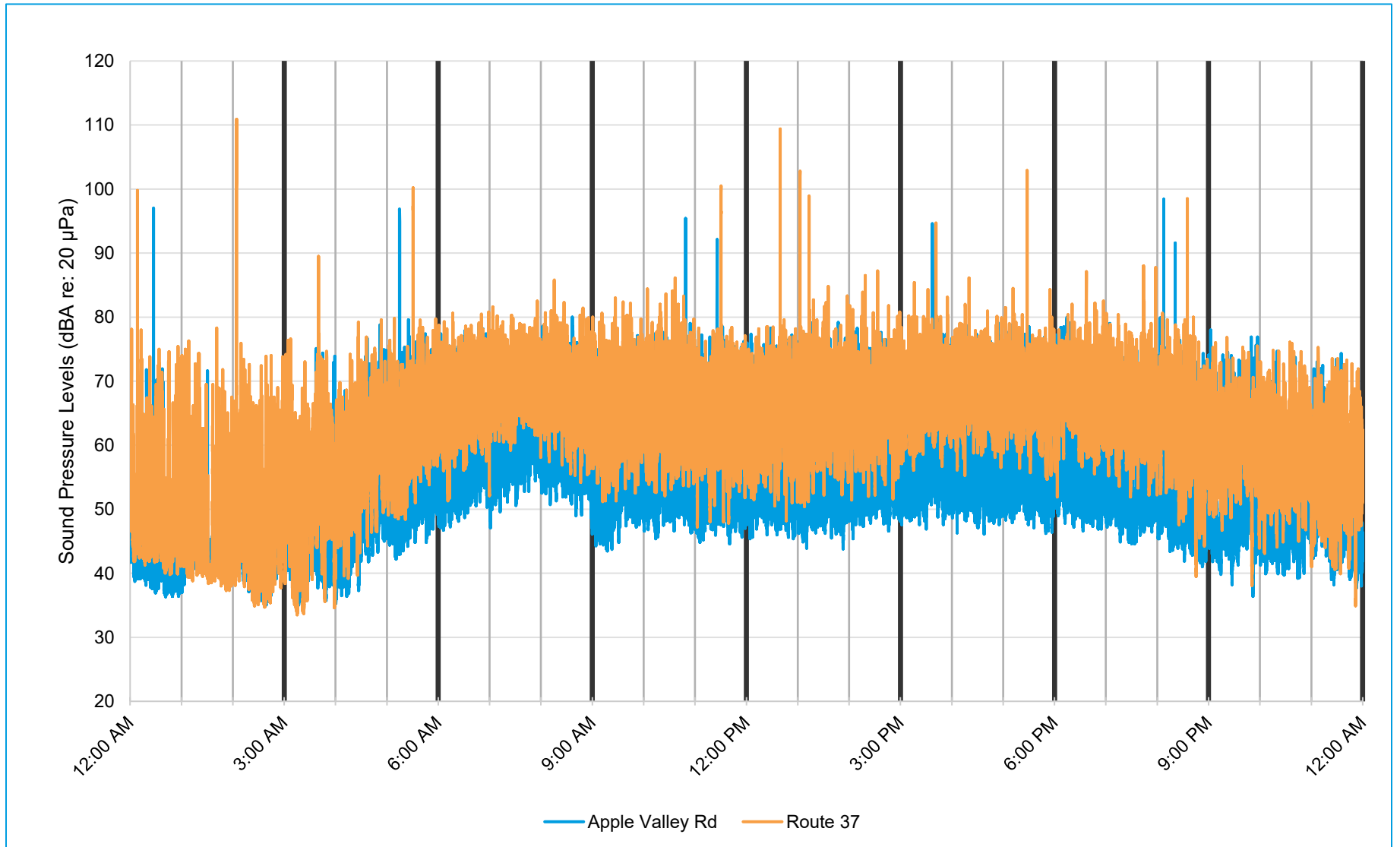



10.24.2025 Logged Data – 1 second L_{eq}

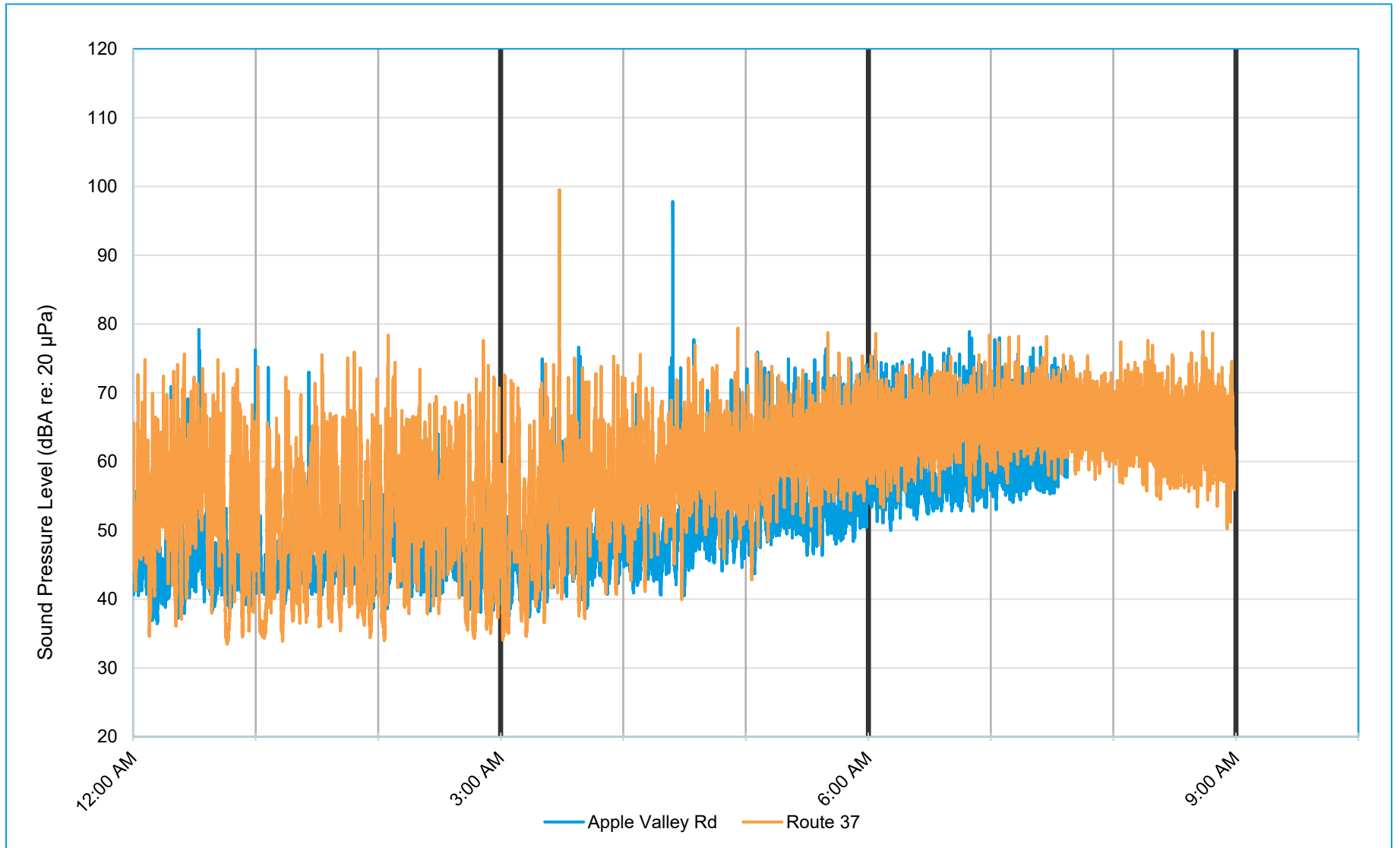

APPENDIX E– SPOT CHECK FREQUENCY DATA

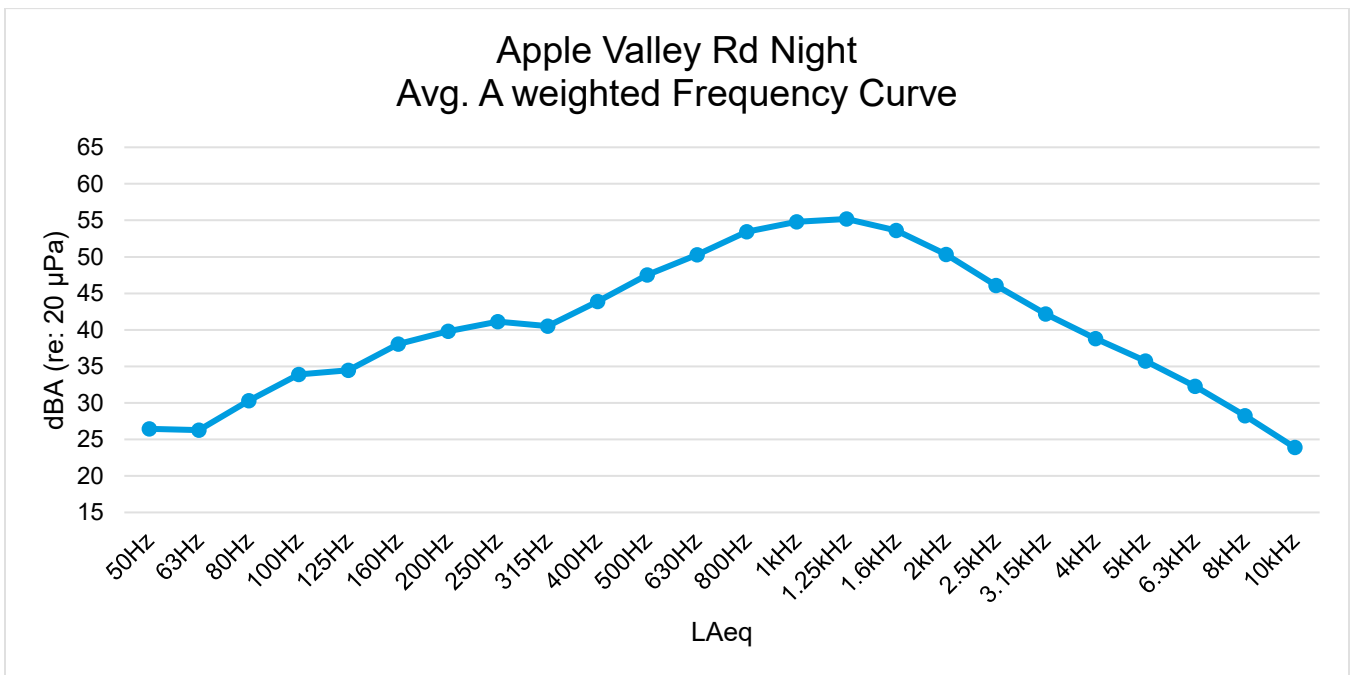
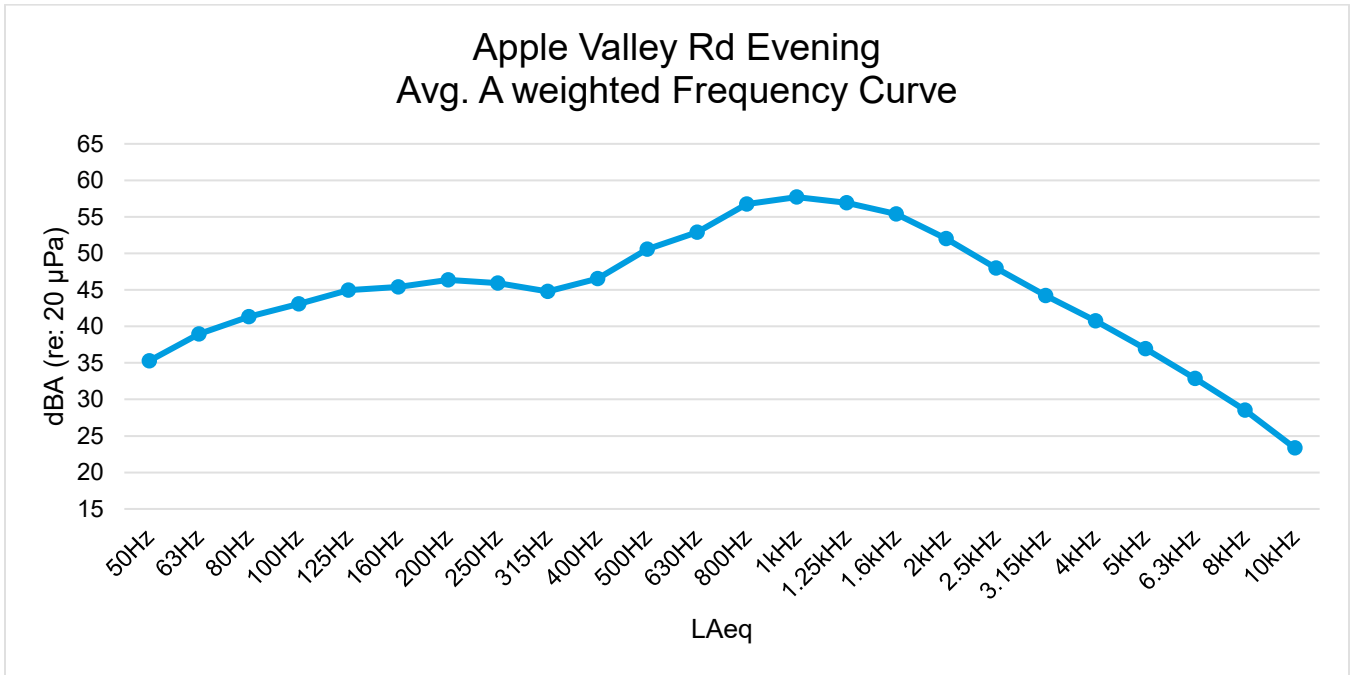



Apple Valley Rd Late Night Avg. A weighted Frequency Curve

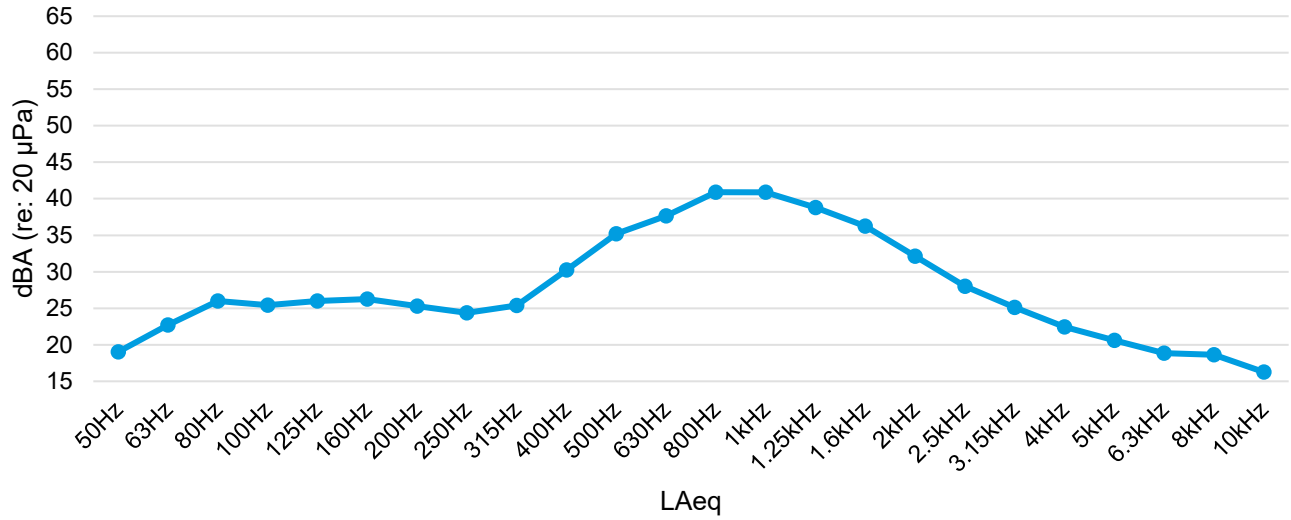

APPENDIX F – PREDICTED SOUND LEVEL MAPS

Normal Operations

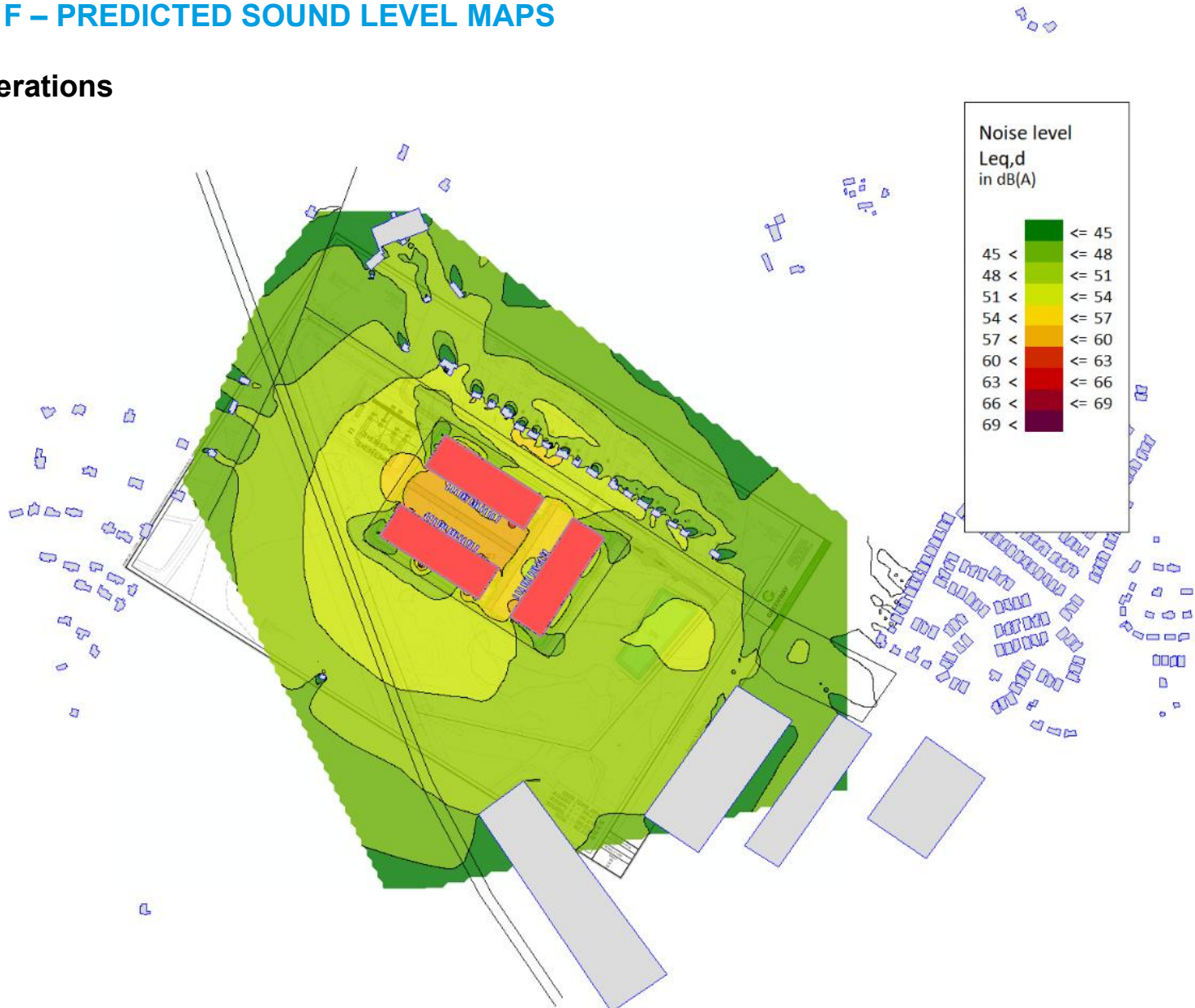

Test Conditions

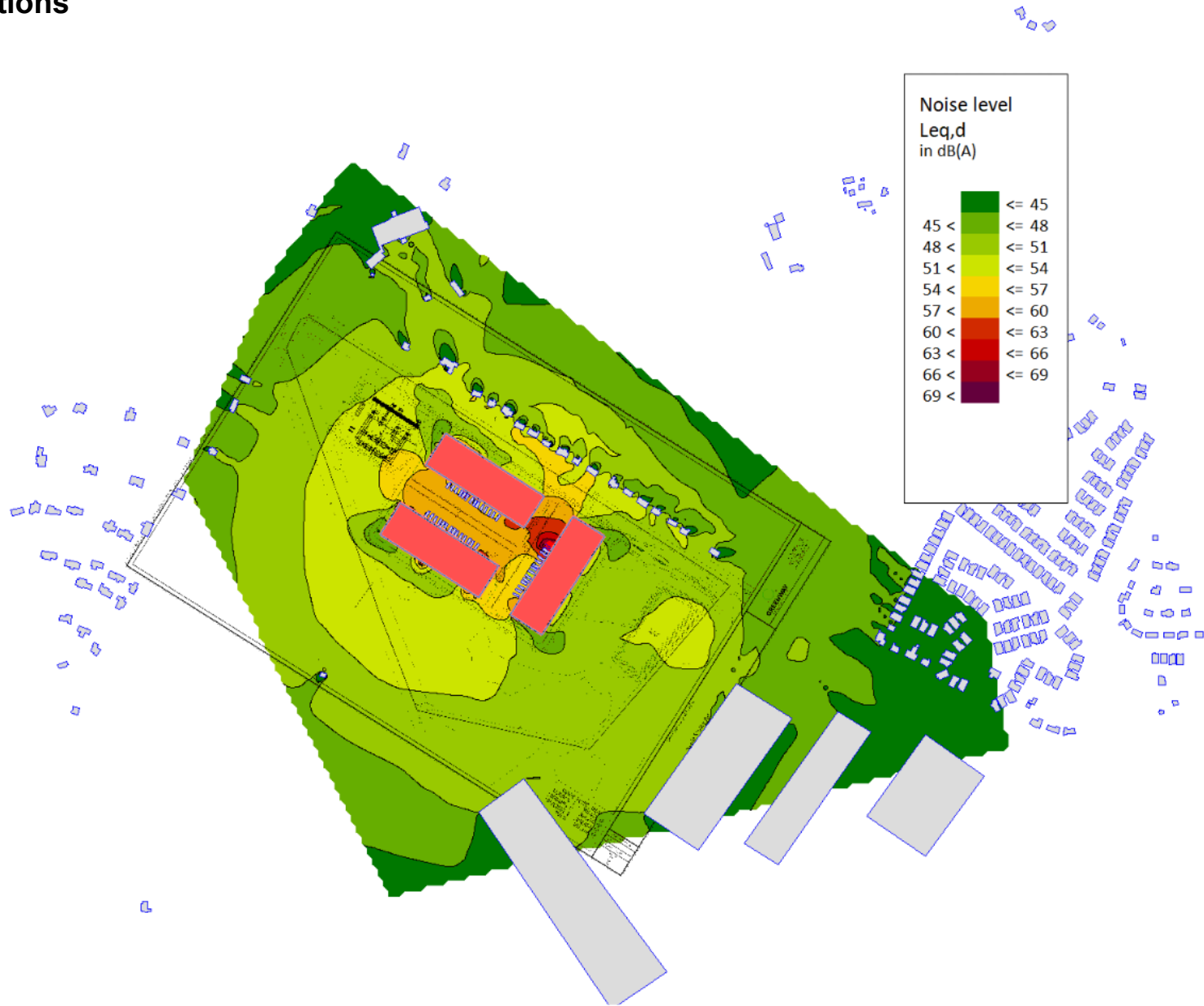



Emergency Conditions

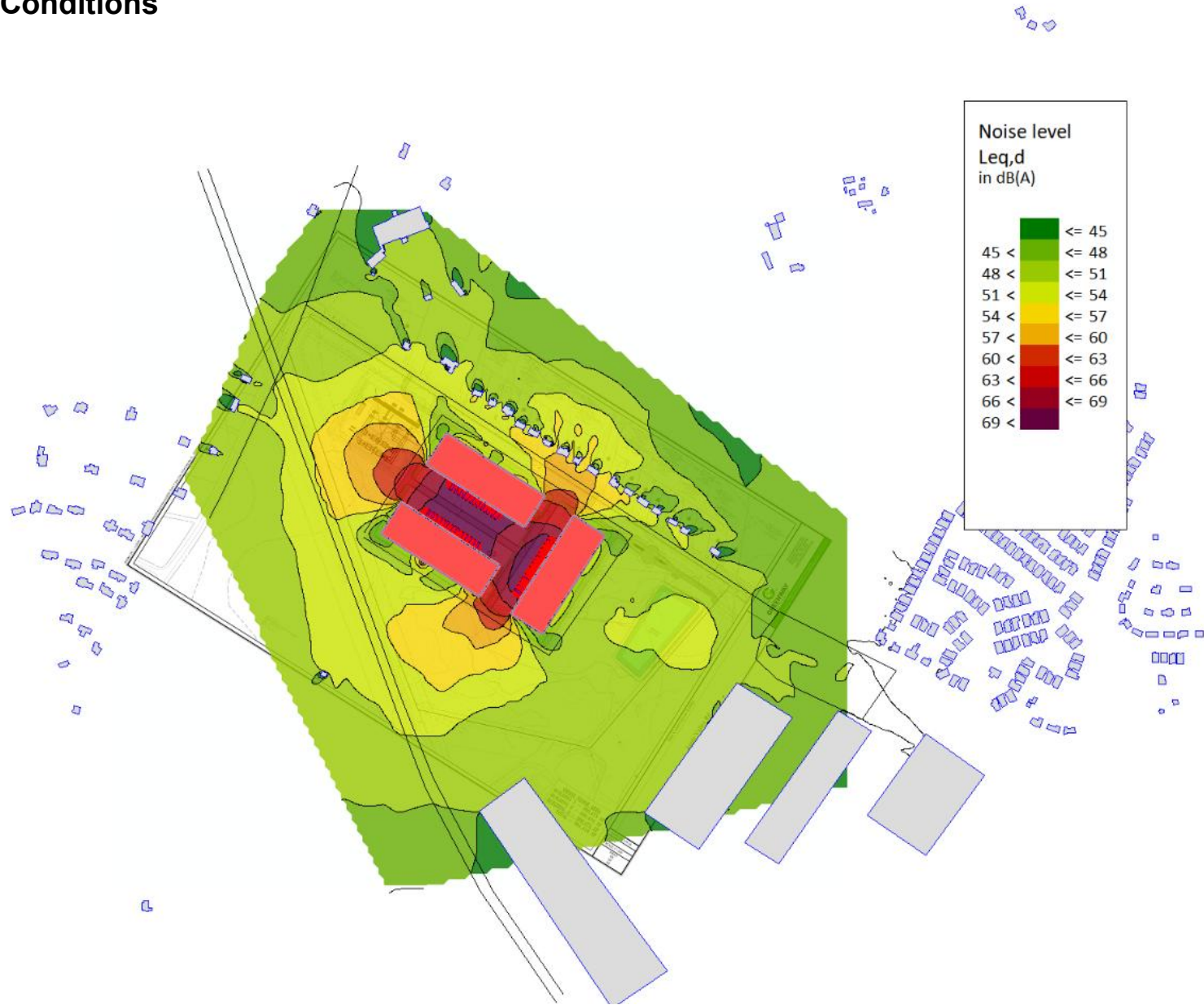

Addendum

Winchester Gateway Data Center – 2565-00642

INTRODUCTION

This report is to provide supplemental information to the previous report dated November 24th, 2025 based on the comments from Cerami dated December 5th, 2025.

APPLICABLE NOISE ORDINANCE

In addition to the sound requirements set forth in the Frederick County Legislation, this project is also subject to the requirements stipulated in the Code of Ordinances for Winchester, Virginia, the applicable sections of both documents have been included in Appendix A.

As the maximum sound levels according to the Winchester Code of Ordinances are more stringent than the Frederick County limits, this project will be held to those levels, but the reporting requirements stipulated in the Frederick County Legislation.

ADDITIONAL SUPPORTING DOCUMENTATION

The Cerami report, dated December 5th, 2025, requested additional documentation including manufacturer cut sheets for mechanical source sound levels and sound attenuation levels of the mufflers or silencers used to achieve the presented levels. This is information that would be provided after the full project design has been completed, this is a preliminary study to fulfill the requirements of Part II.165.204.41-1-A of the Frederick County Legislation to show the project can feasibly achieve the requirements of the local ordinances.

As the Frederick County Legislation also includes requirements for low-noise emission fans, acoustic wraps around any compressors or oil separators, and visual screening and/or acoustic screening for all equipment, these were included in our model and the results of equipment operating without these mitigation efforts should not be up for discussion.

EXISTING CONDITIONS

The previous measurements that were completed from October 22nd-24th, 2025 included both the spot measurements and two different logging meters that were capturing data every second. Additional metrics including the hourly L_{eq} , L_{90} , L_{10} , L_{min} , and L_{max} were calculated and are included in Appendix B. Note that the 24 hour L_{eq} was not included as it would be so driven by the traffic noise that it would not provide an accurate picture of what occurs during the nighttime hours.



The quietest single hour L_{eq} that was measured along Apple Valley Road, nearest the residences, during our time on site was 45 dBA, however, during this same hour the L_{max} was measured at 56 dBA. This shows that there is still noticeable traffic over those nighttime hours that generates noticeable amounts of noise. That peak noise was likely caused by an emergency vehicle siren as that same hour had a corresponding spike at the meter along Route 37 at 111 dBA.

ADDITIONAL MODELING

Additional plots from our acoustic model that include the contribution of the existing noise sources (namely traffic noise along Route 37 and Apple Valley Road) are included in Appendix C. These plots show the different conditions either during typical daytime hours or the quietest nighttime hour.

The only combination that was not included in this is the single generator test condition with nighttime minimum levels as all maintenance testing of the generators will occur during daytime hours.

As this is a representative data center design and not a design that has been fully vetted by all engineering disciplines, it is premature to provide the representative residential point receivers. The approximate impact levels can be seen on the noise sound level maps. The intent of this report is to show the feasibility of the proposed project achieving the limits imposed by the relevant ordinances.

DISCUSSION

The sound level predictions show that there is a feasible path to meeting the noise limits imposed by both the Frederick County Legislation and the Winchester, Virginia Code of Ordinances. During daytime hours, the average noise levels at the property line are anticipated to be in the 66-69 dBA range due to the combination of existing traffic noise along Apple Valley Road and the equipment from the data center.

During the nighttime hours, while the sound levels from the data center will be below the 60 dBA limit, the activity from the data center equipment will significantly raise the L_{min} , L_{90} , L_{eq} and L_{10} and be a clear change in the existing conditions. The peak levels from sirens, motorcycles and heavy vehicles along Route 37 will be reduced because the buildings will provide some acoustic shielding.

Contributors:

ALEX HORNECKER, INCE Bd. Cert.
Senior Consultant, Acoustics
D 469.726.4275
E alex.hornecker@salasobrien.com

Aaron Walker
Acoustic Designer
D 303.472.0779
E aaron.walker@salasobrien.com



APPENDIX A – APPLICABLE ORDINANCES

Frederick County Legislation Part II Chapter 165 Part 204.41 for Data Center projects as of December 10th, 2025:

- A. *Prior to the approval of a rezoning application or conditional use permit, the following shall be provided:*
 - (1) *A site assessment to examine the sound profile of the data center on residential units and schools located within 500 feet of the data center property boundary in accordance with Subsection E.*
- B. *Generator testing and cycling shall be limited to weekdays (Monday to Friday) between the hours of 8:00 a.m. to 5:00 p.m. Notwithstanding the foregoing, all noise generated by any on-site generator shall comply with County Code § 165-201.12. [Section 165-201.12.H Specifies a property line limit that shall not exceed 70 dBA.]*
- C. *Mechanical equipment.*
 - (1) *Location. Ground-mounted mechanical equipment shall be prohibited in the primary setback.*
 - (2) *Screening. Ground-mounted and rooftop mechanical equipment shall be screened from public roadways and adjoining properties on all sides.*
 - (3) *Generators. All generators shall be enclosed with a manufacturer-approved enclosure or located within the primary structure.*
 - (4) *Other mechanical equipment. An opaque screen shall be provided by either the principal building, louvered wall, or equivalent screen approved by the Zoning Administrator. The maximum height of the opaque screen should correspond to the tallest piece of equipment being shielded from view.*
- D. *Setback and screening requirements.*
 - (1) *Structures must be set back at least 200 feet from the common property line when adjoining land is zoned RA, RP, R4, R5 and MH1. Otherwise, the base zoning district dimensional standards shall apply.*
 - (2) *A category C full-screen-type buffer shall be provided around the perimeter of the property. If the adjoining property is zoned B3, TM, M1, or M2, no buffer is required.*
- E. *Noise and noise monitoring.*
 - (1) *The applicant shall submit an Environmental Noise Impact Assessment prepared by a qualified full member of the Acoustical Society of America (ASA), a member of the Institute of Noise Control Engineering (INCE), or a member of the National Association of Acoustical Consultants (NCAC). The purpose of such noise impact assessment, modeled in SoundPLAN, CadnaA, or accepted equivalent, shall model anticipated noise levels as a result of facility operation and establish a baseline noise level prior to approval of a rezoning or conditional use permit.*
 - (2) *A noise study certifying noise levels shall be conducted 12 months after the issuance of the first certificate of occupancy (CO) and every five years thereafter. Each noise study shall be submitted for review to the Zoning Administrator and/or his/her designee to assess the actual impact of the completed project.*
 - (a) *The measurement of sound or noise pursuant to this section shall be as follows:*
 - [1] *The measurement of sound or noise shall be made with a Type 1 or Type 2 sound level meter which meet the standards prescribed in ANSI S1.4:2014, Specification for Sound Level Meters. The instruments shall be maintained in calibration and good working order. A minimum of three sound level readings shall be taken. The average of these readings will be used as the average sound level. If the background noise is equal to the levels set forth in this section, 3 dB shall be subtracted out of the average sound level.*
 - [2] *The slow meter response of the sound level meter shall be used to determine that the average amplitude has not exceeded the dBA readings or the limiting noise spectra set forth in this section.*



- [3] Unless otherwise specified, the measurement shall be taken at the property boundary on which such noise is generated.*
- (b) Any additions, alterations, or expansion of a facility or its equipment shall require a new noise impact assessment to be submitted and approved by the Zoning Administrator.*
 - (c) If the post construction noise study exceeds the maximum noise level permitted, additional noise mitigation strategies, improvements, or operational changes shall be required.*
- (3) Any equipment necessary for cooling, ventilating, or otherwise operating the facility, including power generators or other power supply equipment on the property, whether ground-mounted or roof-mounted, shall include the following noise-mitigation elements:*
- (a) Low-noise emission fans.*
 - (b) Acoustic wraps for compressors and oil separators.*
 - (c) An acoustic perimeter, which may include a perimeter around a group of individual chillers, which may be louvered or solid.*
 - (d) Other sound-attenuation measures as approved by the Zoning Administrator.*

The owner shall provide documentation, in the form of technical specifications, photographs, and/or engineered plans, of the above mitigation measures contained in Subsection E(3) with each building permit for a data center building on the property and shall further provide documentation that such measures have been installed concurrently with each occupancy.

Winchester, Virginia – Code of Ordinances Chapter 17 as of December 3rd, 2025:

Sec. 17-6. - Noises prohibited—Enumeration.

The following acts shall be unlawful:

- (4) To permit, operate, or cause any source of sound to create a sound level in another person's residential dwelling in excess of 65 dBA when measured inside the receiving structure at least four feet from the wall nearest the source, with doors and windows to the receiving area closed.*

Sec. 17-7.1. - Maximum nighttime sound levels in residential zones.

No person shall operate or cause any source of sound in such a manner as to create a sound level in a residential zone during the hours between 10:00 p.m. and 6:00 a.m. in excess of 60 dBA when measured at the property boundary of the receiving land. The foregoing shall not be deemed to include sound generation from any bona fide agricultural activity, including noise caused by livestock.



APPENDIX B – 1-HOUR METRICS

The previous measurements that were completed from October 22nd-24th, 2025 included both the spot measurements and two different logging meters that were capturing data every second. The following additional metrics were calculated based on those logged results.

Date	Hour	Apple Valley Road					Route 37				
		L _{min}	L ₉₀	L _{eq}	L ₁₀	L _{max}	L _{min}	L ₉₀	L _{eq}	L ₁₀	L _{max}
10/22/2025	11:00	46	51	66	64	94	47	53	59	62	74
	12:00	43	48	62	65	79	45	52	59	62	71
	13:00	46	50	67	63	98	45	53	59	62	74
	14:00	46	51	63	67	77	46	55	65	69	83
	15:00	47	51	66	70	92	53	63	70	73	88
	16:00	47	50	64	70	77	53	62	70	73	81
	17:00	46	51	65	70	80	55	63	70	73	86
	18:00	47	50	69	68	100	55	62	69	72	86
	19:00	43	47	59	57	76	52	58	67	71	84
	20:00	42	47	61	61	78	47	56	67	70	85
	21:00	38	43	57	56	78	42	52	63	67	77
	22:00	38	42	52	52	74	41	48	61	65	78
23:00	38	41	54	53	76	41	44	59	62	76	
10/23/2025	0:00	36	38	64	49	97	40	42	68	60	100
	1:00	37	40	45	46	72	37	40	57	59	78
	2:00	35	37	44	48	56	35	38	79	62	111
	3:00	35	37	51	50	75	34	37	62	62	90
	4:00	35	41	55	53	79	39	49	61	65	80
	5:00	42	47	67	59	97	48	55	71	70	100
	6:00	47	51	62	63	79	51	61	70	73	81
	7:00	47	53	64	68	78	58	65	71	74	83
	8:00	46	54	65	70	80	54	62	71	74	86
	9:00	44	48	62	65	79	51	59	69	72	83
	10:00	45	49	66	64	95	52	59	69	72	86
	11:00	45	49	64	65	92	47	57	71	71	101
	12:00	45	49	63	68	78	48	58	77	71	109
13:00	44	48	62	63	79	50	58	75	73	103	



	14:00	45	50	64	69	78	51	60	70	72	87
	15:00	47	51	66	71	95	56	63	71	74	95
	16:00	46	50	65	70	79	55	64	71	74	86
	17:00	46	50	64	69	79	55	64	74	74	103
	18:00	47	50	63	66	80	52	63	70	73	87
	19:00	45	48	61	61	79	52	59	69	72	88
	20:00	41	46	67	59	98	40	54	69	71	99
	21:00	36	43	58	59	78	38	54	63	67	77
	22:00	39	43	52	52	75	43	52	62	66	76
	23:00	38	42	54	54	74	35	47	61	65	75
10/24/2025	0:00	36	40	53	51	79	34	40	60	64	76
	1:00	39	41	51	51	74	34	37	58	61	76
	2:00	38	41	49	52	64	34	39	59	62	78
	3:00	37	41	52	52	77	34	40	67	62	100
	4:00	41	45	66	55	98	40	52	61	64	79
	5:00	44	50	59	59	76	43	56	64	67	79
	6:00	50	54	62	62	79	53	60	66	69	79
	7:00	53	56	61	64	78	57	62	68	70	78
	8:00	-	-	-	-	-	50	58	67	70	79

APPENDIX C – SOUND LEVEL MAPS WITH EXISTING SOURCE CONTRIBUTIONS

Normal Operations – Day

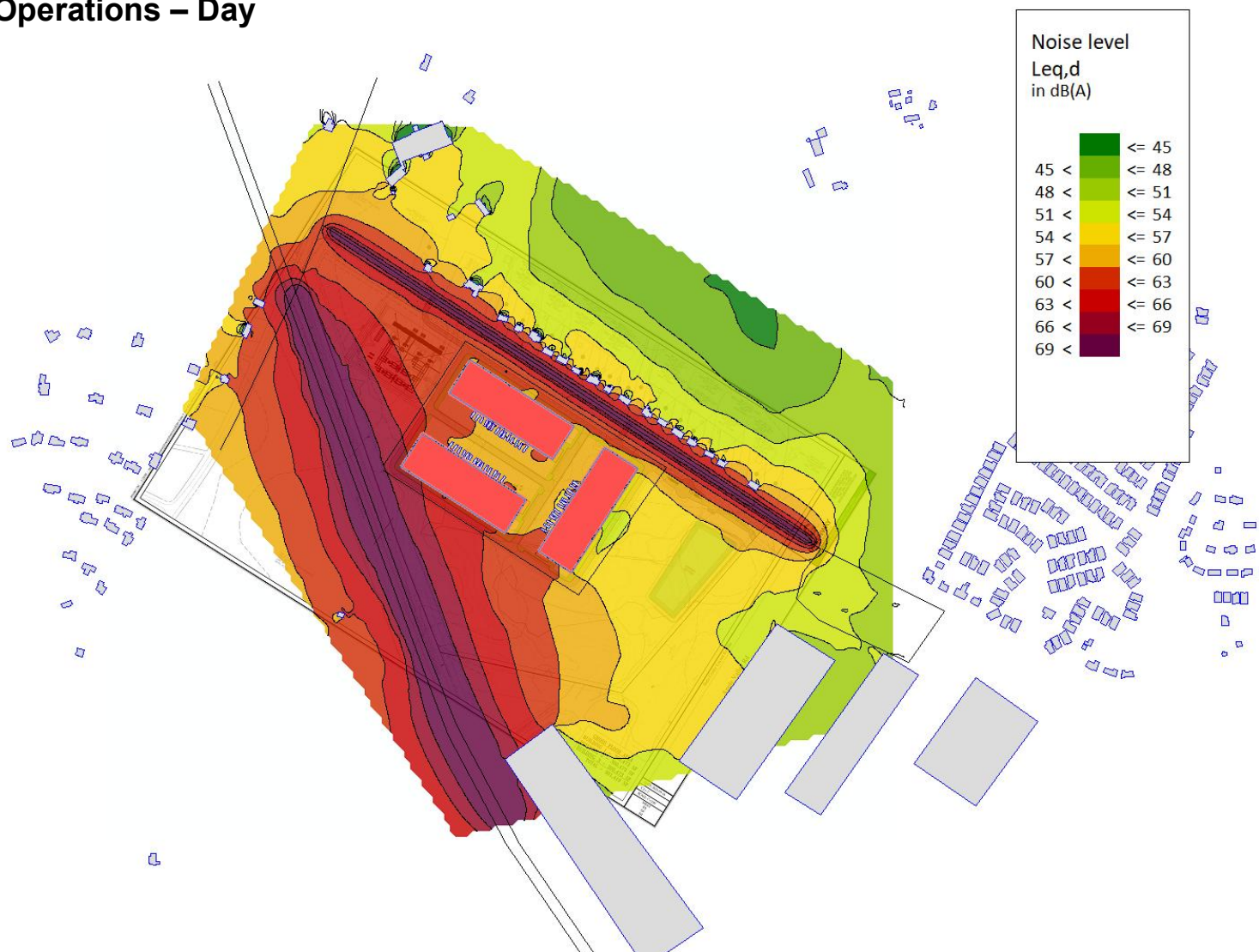

Normal Operations – Night

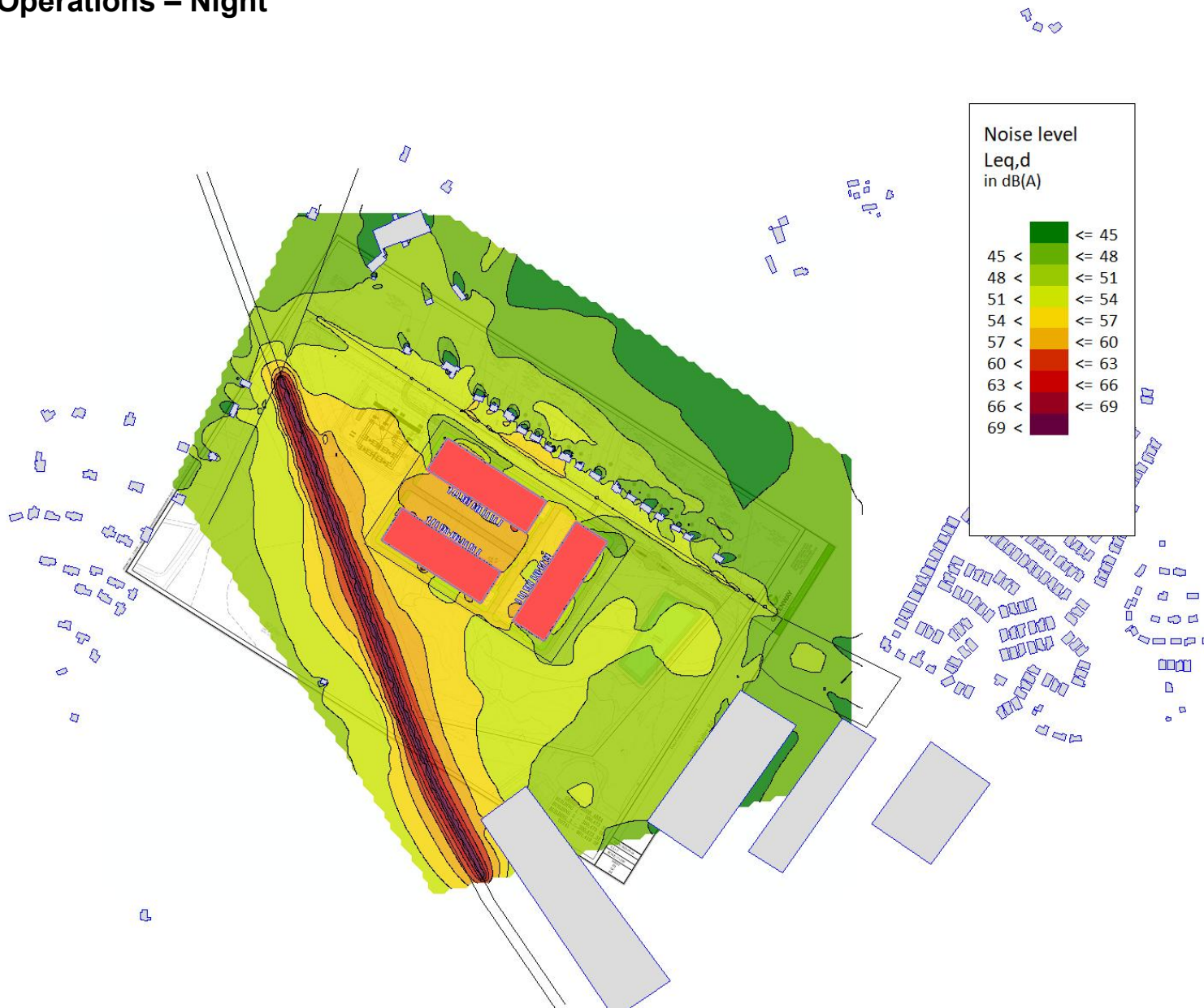



Test Conditions – Day

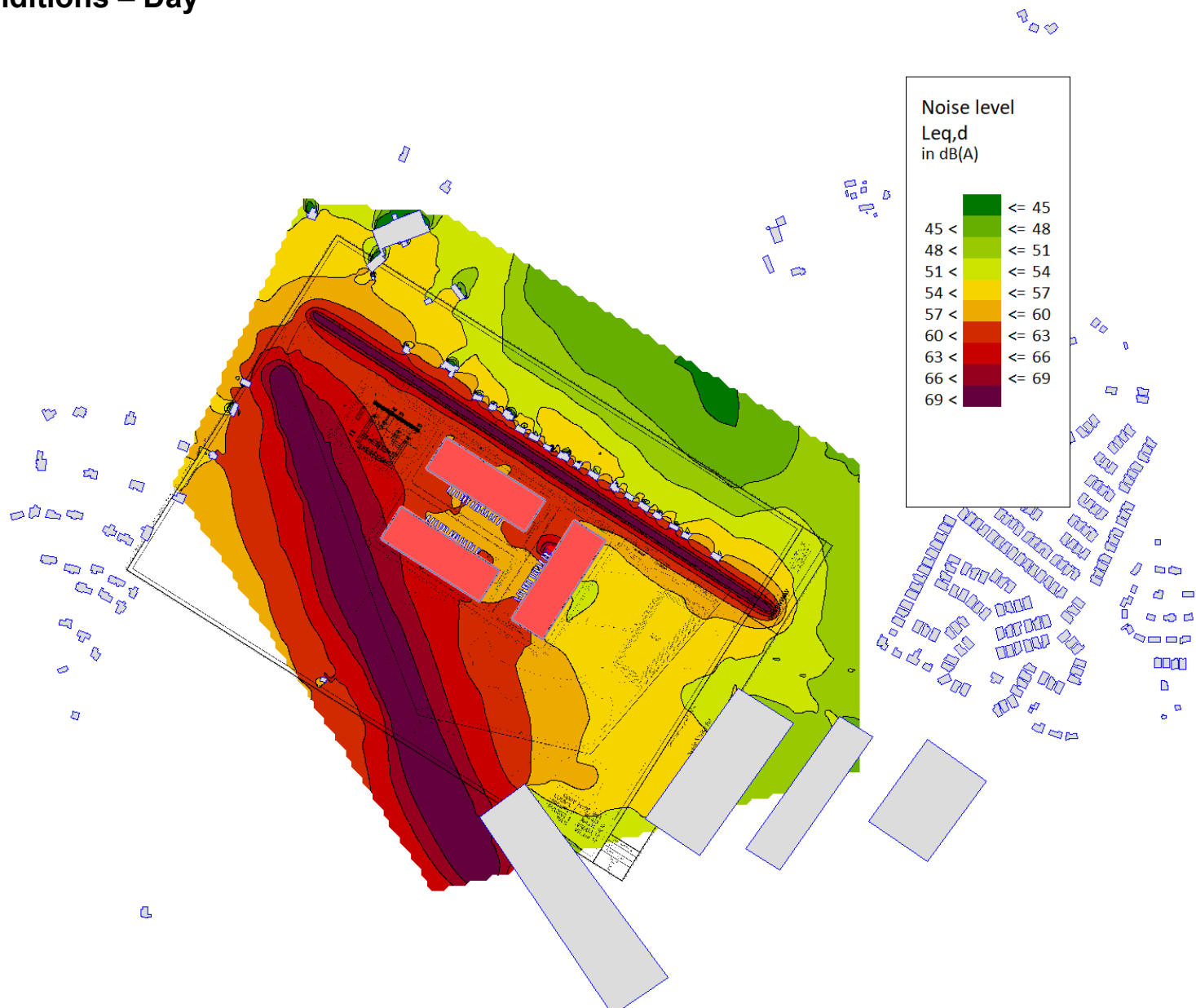

Emergency Conditions – Day

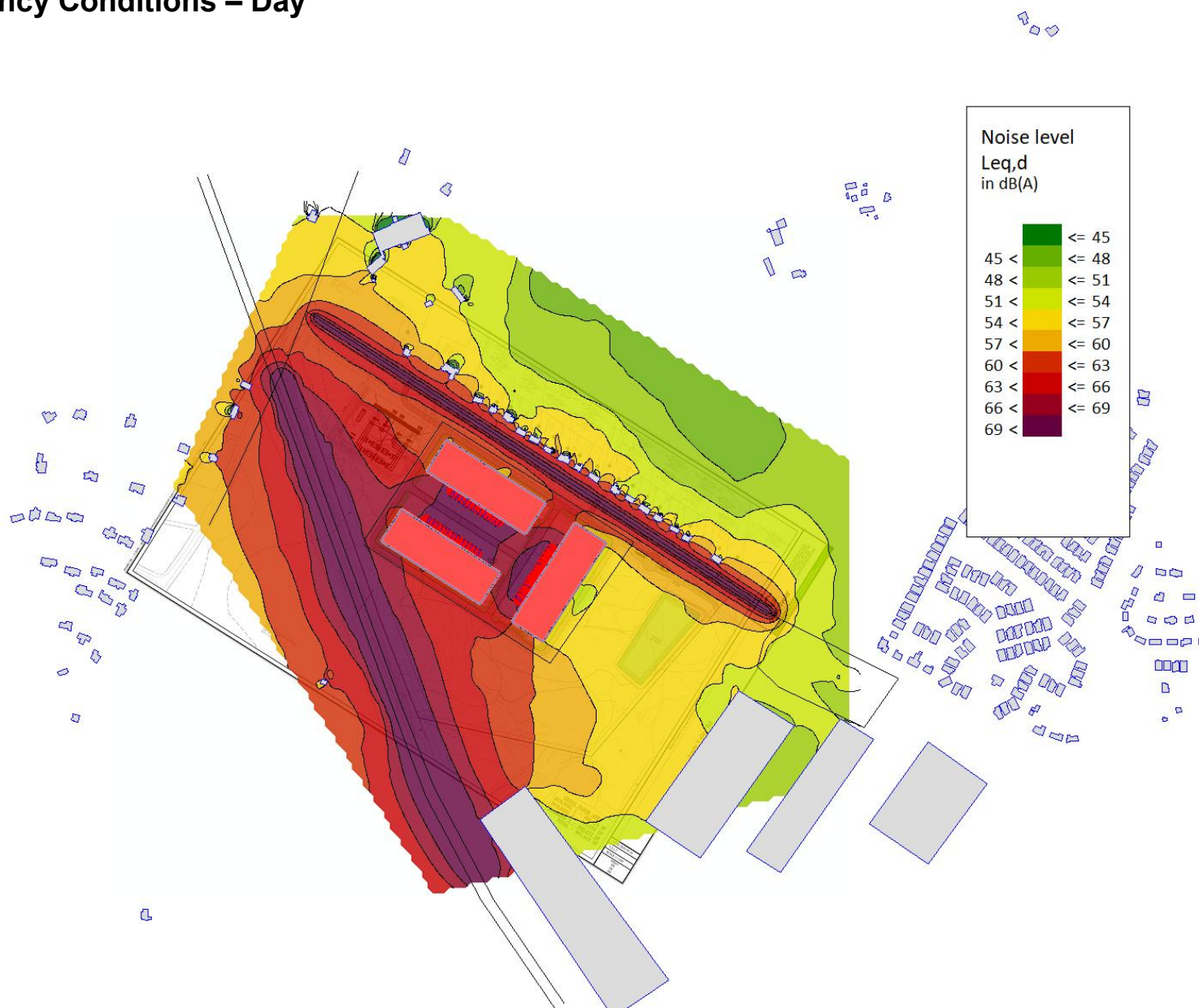



Emergency Conditions – Night

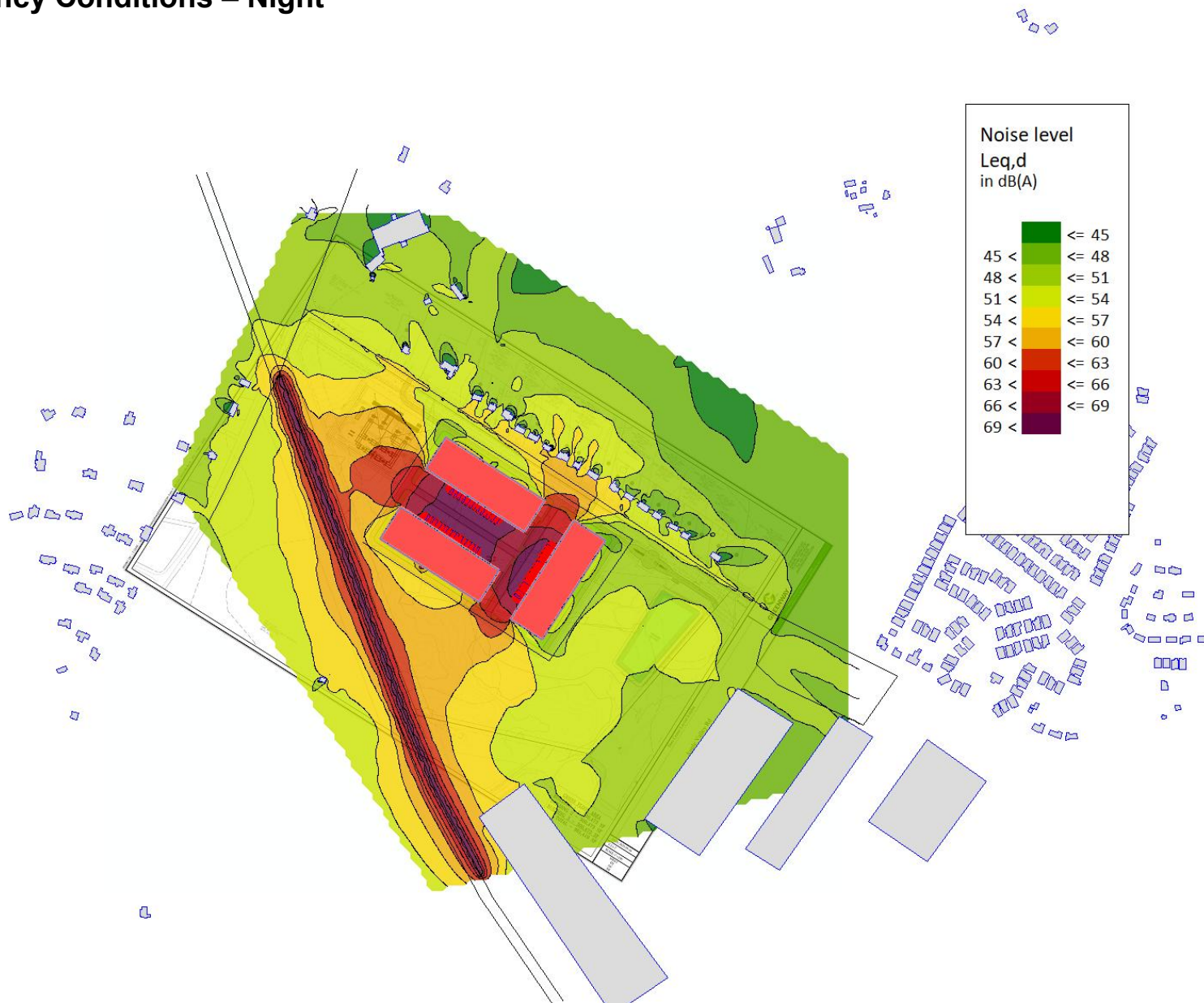

Addendum 2

Winchester Gateway Data Center – 2565-00642

INTRODUCTION

This report is to provide supplemental information to the previous report dated November 24th, 2025 based on the comments from Frederick County dated January 23, 2026.

METHODS AND EQUIPMENT

The spot measurements were done using a type 1 sound level meter to collect frequency data:

- SLM 1
 - Brüel and Kjær 2250 serial # 2506423
 - Mic type Brüel and Kjær 4189 serial # 2933077
 - Field calibrated

The 24 hour unattended measurements were done using type 2 sound level meters using 1 second logging:

Equipment:

- LSLM 1
 - Extech SDL600 serial # 453092
 - Field calibrated
- LSLM 2
 - Extech SDL600 serial # 453045
 - Field calibrated
- Microphone Calibrator
 - B&K 4231 serial # 2518080

MEASUREMENT LOCATIONS

Short term measurements were taken along Middle Rd see Appendix C. The measurement at the Northeast corner was in line with the other measurements along Route 37 and the measurements at the Northwest corner was in line with the other measurements along Apple Vally Rd.

These primary sources at each corner were identified to be either Route 37 and Apple Valley Rd respectively, and the sound was characterized in each of those categories.

PROPERTY LINE PREDICTIONS

Daytime noise level (dBA) at property line inclusive of existing ambient traffic levels:

	Normal Operations	Test Conditions	Emergency Conditions
North	65	66	66
Northwest	65	65	65
Southwest	70	70	70
South	54	54	56
East	65	65	65

Nighttime noise level (dBA) at property line inclusive of existing ambient traffic levels:

	Normal Operations	Test Conditions	Emergency Conditions
North	55	56	59
Northwest	47	47	50
Southwest	59	59	60
South	51	51	53
East	53	53	53

EQUIPMENT

The equipment selection indicated here is preliminary and while indicative of potential intent, will undergo substantial changes, in either (or both) quantities of equipment and equipment selections, once a mechanical engineer has completed a full design package. The cutsheets for the equipment used in this study is included on the following pages.

Significant quantities of mechanical sources of noise were placed according to the layout on page 10 of the initial report.

Contributors:

ALEX HORNECKER, INCE Bd. Cert.
Senior Consultant, Acoustics
D 469.726.4275
E alex.hornecker@salasobrien.com

Aaron Walker
Acoustic Designer
D 303.472.0779
E aaron.walker@salasobrien.com

CRAC Submittal

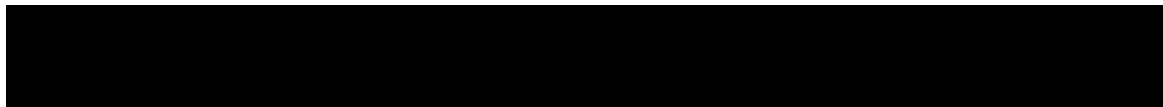

Presented to:



Equipment Manufacturer
AboveAir Technologies
5179 Mountville Rd
Frederick, MD 21703



Manufacturer's Representative
AirReps, LLC
3290 146th Place SE, Suite F
Bellevue, WA 98007

AboveAir Technologies, LLC

5179 Mountville Road., Frederick, Maryland 21703 USA

Tel: 301-874-1130 Fax: 301-874-1131

FOR APPROVAL - EQUIPMENT SUBMITTAL

Project: [REDACTED]

Engineer: N/A

Contractor: [REDACTED]

AboveAir Rep: Air Reps, LLC

AboveAir Technologies Equipment:

Tag: CRAC-1-1,2,3,4; Qty. Four(4)

Model MCE-097D-4-ESH-AE-1D-EC-DFB-E, 27.5 Ton

Nom., MC2 MissionCritical™, Split DX Evaporator, (460/3/60) w/ Qty. Four(4) Model XPX-097D-4-00-00-00-VF-FL, DX-Air Cooled Remote Outdoor Condenser, (460/3/60).

Tag: CRAC-1-5,6; Qty. Two(2)

Model MCE-105D-4-ESH-AE-1D-EC-DFB-E, 30.0 Ton Nom.,

MC2 MissionCritical™, Split DX Evaporator, (460/3/60) w/ Qty. Two(2) Model XPX-105D-4-00-00-00-VF-FL DX-Air Cooled Remote Outdoor Condenser, (460/3/60).

Note:

If applicable, Compressor Sound Jacket, Voltage/Phase Monitor, Hose Kit, Spare Filters, Refrigerant piping, Secondary Drain Pans, Rigging, Installation, Labor & Labor Warranty to be supplied by others.

AboveAir Technologies

Date: November 14, 2024

Submitted by:

Submittal Comment Responses

11/14/2024 - Rev 1

1. The correct condenser nomenclature is XPX. The XP2 nomenclature in the spec is a previous model number for the same unit. AboveAir do not have an updated spec reflecting the change. There is no effect to the equipment being provided.
2. Updated unit tags to "CRAC".
3. Yes, all units provide 15,000 CFM of cooled air at the specified altitude.
4. There factory mounted temperature sensor in the mixed air section of the unit to measure the temperature from the mixing box for economizer control.
5. 24V, 100VA transformers were coordinated for previously approved sites. I discussed with Lu at Salas and he approved proceeding with 24V. Once actuator submittals are received he will confirm sufficient transformer capacity.
6. Humidifiers were revised to 30 lbs/hr capacity with no impact to cost.
7. AboveAir does not offer a labor warranty. Labor warranty will be provided by Air Reps.

Unit Tag	CRAC-1-1,2,3,4	Project	[REDACTED]
Evap Model, Qty (4)	MCE-097D-4-ESH-AE-1D-EC-DFB-E	Engineer	Salas O'Brien
Cond Model, Qty (4)	XPX-097D-4-00-00-00-VF-FV	Contractor	TBD
Unit Type	27.5 Ton (Dual/Lead Digital) Nom. MC	AboveAir Rep	Air Reps (Zach Levine)
	ACU w/ Split Condenser	Date	14-Nov-24

Electrical Data **65k SCCR**

Evap Section Power	460-480/3/60
Evap Nameplate	101.5 FLA 116.7 MCA 125 MOP
Cond Section Power	460-480/3/60
Cond Nameplate	9.3 FLA 11.6 MCA 20 MOP

Condenser Data

Total Heat of Rej.	454.8 MBh
Coil Construction	Aluminum Finned, Copper Tube
Airflow	22,000 cfm @ 0.00 in w.g. ESP
Fan Type, Qty (2)	ECM Axial Fan
Low Ambient Control	Variable Speed Fan (-20°F)
Motor kW / FLA (each)	3.4 kW / 4.7 FLA

Design Ambient Conditions

Summer	104.6°F DB / 78.4°F WB
Winter	-2.0°F DB

Dual Cool Coil Data

Gross Capacity	N/A
Net Capacity	N/A
EAT / LAT	N/A
EWT / LWT	N/A
GPM @ Ft Hd	N/A
Fluid Type	N/A
Face Area / Rows / FPI	N/A
Construction	N/A
Control Valve	N/A
Control Valve Cv	N/A

Design Space/Return Conditions

Cooling	85.0°F DB / 67.0°F WB
Heating	70.0°F DB

Supply Air Fan Data

Total Airflow Rate	15,000 cfm 164' Altitude
Outdoor Airflow Rate	00 cfm OA / 0.0%
ESP / TSP	0.30 in w.g. / 1.23 in w.g.
Fan Type, Qty (3)	ECM Direct Drive BI Impeller
Motor kW / FLA (Each)	4.5 kW / 5.9 FLA
Fan Speed Control	Constant Speed

Unit Mounted Heat Data

Type	SCR Electric Heat
Capacity / FLA	30.0 kW / 37.7 FLA
Operation	Reheat/Heat
EAT / LAT	63.2°F / 69.5°F
EWT / LWT	N/A
GPM @ Ft Hd	N/A
Fluid	N/A
Face Area / Rows / FPI	N/A
Construction	Stainless Steel Elements
Control Valve	N/A
Control Valve Cv	N/A

Cooling Coil Data

Gross Capacity	357.5 TMBh / 354.8 SMBh
Net Capacity	341.1 TMBh / 338.4 SMBh
Mixed EAT	85.0°F DB / 67.0°F WB
Coil LAT	63.2°F DB / 59.4°F WB
Condensate Flow	6.8 lb/hr
Face Area / Rows / FPI	28.2 ft² / 3 / 12
Construction	Aluminum Finned, Copper Tube

Hot Gas Reheat Coil Data

Capacity	N/A
LAT (@ Max Output)	N/A
Face Area / Rows / FPI	N/A
Construction	N/A
Control	N/A

Humidification Data

Type	Steam Canister
Steam Capacity / FLA	30 lb/hr / 12.8 FLA
Operation	Always Available

Compressor Data

Comp 1 Type	Digital Scroll
Comp 1 LRA / RLA	150.0 LRA / 23.1 RLA
Comp 2 Type	Fixed Speed Scroll
Comp 2 LRA / RLA	150.0 LRA / 23.1 RLA
Location	Evaporator Section
Refrigerant Type	R-410a

- Unit Configuration & Airflow Patterns**
- Downflow: Free or Ducted Top Return/Bottom Discharge
 - Top Piping Connections
 - Remote Free Discharge Split Condenser
 - No Plenum Box
 - 12" High (Adj. 11.2"-14") Field Installed Seismic Floor Stand
 - **Seismic Construction, Evaporator and Condenser**

Refrigerant Field Connections

Indoor Unit (Qty 2 ea.) 3/4"OD Liq & 1 1/8" OD Discharge
Indoor HG Reheat N/A
Outdoor Unit (Qty 2 ea.) 3/4"OD Liq & 1 1/8" OD Discharge
Outdoor HG Reheat N/A

Connection Data

Condensate Drain 1/2" OD
Humidifier Supply 1/4" OD Copper
Hot Water N/A
Dual Cool N/A

Air Filtration Data

Filter Qty (4) 20x25x4 &
Qty (4) 16x25x4 (Merv 13)

Physical Data

Dimensions See attached cut sheet
Evap / Cond Weight 3100 lb / 1715 lb

Coil Coatings

- Supply Air Coils - No Coatings
- Condenser Coil - No Coatings

Factory Installed Optional Accessories

- Through-Door Main Power Disconnect (Evap Section) 65k SCCR
- Condensate Pump (48' lift)
- Firestat
- Smoke Detector

- Fused Disconnect (Cond Section) 65 kA SCCR

Field Installed Optional Accessories

- Water Detector (Probe/Spot Type)
- Neoprene Vibration Isolators (Evap Section)
- Extra Filters (1 Set)

Control Type

- MC-Series Advanced Microprocessor w/ Alarms

Control Sequence

- MC-2000S RH Std DX Temp & Humidity Control

Sensors & Displays

- Unit Mtd Human Machine Interface (HMI)
- Wall Mounted Temperature & Humidity Sensor
- Duct Mounted OA Temperature Sensor
- Unit Mounted Return Air Temperature Sensor

Control Options

- BMS Card (BACnet MSTP)
- Multi-Unit Sequencing
- Airside Economizer - Dry Bulb + Enthalpy Control

Factory Warranties (Labor Not Included)

- 1 Year Limited Parts Warranty
- Extended 2 Year (Total 3 Years) Control Board and Humidifier Warranty (Parts Only)
- Extended 4 Year (Total 5 Years) Compressor Warranty

Select Standard Design Features

- Heavy Duty Gavanneal Steel Construction
- High Efficiency Scroll Compressor
- TXV with External Equilization
- High & Low Refrigerant Pressure Safety Switches
- Stainless Steel Drain Pan with Overflow Safety Switch
- Intertek (ETL) UL STD 1995 Listed/Labeled
- Factory installed and tested controls
- Each unit factory tested per UL 1995 Requirements

System Notes

1. System ships with a dry nitrogen charge.
2. Do not install refrigerant piping based upon connection sizes. Refrigerant piping runs must be sized according to piping requirements at www.aboveairioms.com.
3. Max total equivalent line length is 150 feet.
4. Include 24V, 100VA transformer to power field provided damper.

Unit Tag	CRAC 1-5, 1-6	Project	████████████████████
Evap Model, Qty (2)	MCE-105D-4-ESH-AE-1D-EC-DFB-E	Engineer	Salas O'Brien
Cond Model, Qty (2)	XPX-105D-4-00-00-00-VF-FV	Contractor	TBD
Unit Type	30.0 Ton (Dual/Lead Digital) Nom. MC ACU w/ Split Condenser	AboveAir Rep	Air Reps (Zach Levine)
		Date	14-Nov-24

Electrical Data

65k SCCR

Evap Section Power	460-480/3/60
Evap Nameplate	109.2 FLA 125.3 MCA 150 MOP
Cond Section Power	460-480/3/60
Cond Nameplate	9.3 FLA 11.6 MCA 20 MOP

Design Ambient Conditions

Summer	104.6°F DB / 78.4°F WB
Winter	-2.0°F DB

Design Space/Return Conditions

Cooling	85.0°F DB / 67.0°F WB
Heating	70.0°F DB

Supply Air Fan Data

Total Airflow Rate	15,000 cfm 164' Altitude
Outdoor Airflow Rate	00 cfm OA / 0.0%
ESP / TSP	0.30 in w.g. / 1.23 in w.g.
Fan Type, Qty (3)	ECM Direct Drive BI Impeller
Motor kW / FLA (Each)	4.5 kW / 5.9 FLA
Fan Speed Control	Constant Speed

Cooling Coil Data

Gross Capacity	391.9 TMBh / 390.7 SMBh
Net Capacity	375.5 TMBh / 374.3 SMBh
Mixed EAT	85.0°F DB / 67.0°F WB
Coil LAT	61.0°F DB / 58.6°F WB
Condensate Flow	4.6 lb/hr
Face Area / Rows / FPI	28.2 ft² / 3 / 12
Construction	Aluminum Finned, Copper Tube

Hot Gas Reheat Coil Data

Capacity	N/A
LAT (@ Max Output)	N/A
Face Area / Rows / FPI	N/A
Construction	N/A
Control	N/A

Compressor Data

Comp 1 Type	Digital Scroll
Comp 1 LRA / RLA	173.0 LRA / 26.9 RLA
Comp 2 Type	Fixed Speed Scroll
Comp 2 LRA / RLA	173.0 LRA / 26.9 RLA
Location	Evaporator Section
Refrigerant Type	R-410a

Condenser Data

Total Heat of Rej.	509.8 MBh
Coil Construction	Aluminum Finned, Copper Tube
Airflow	22,000 cfm @ 0.00 in w.g. ESP
Fan Type, Qty (2)	ECM Axial Fan
Low Ambient Control	Variable Speed Fan (-20°F)
Motor kW / FLA (each)	3.4 kW / 4.7 FLA

Dual Cool Coil Data

Gross Capacity	N/A
Net Capacity	N/A
EAT / LAT	N/A
EWT / LWT	N/A
GPM @ Ft Hd	N/A
Fluid Type	N/A
Face Area / Rows / FPI	N/A
Construction	N/A
Control Valve	N/A
Control Valve Cv	N/A

Unit Mounted Heat Data

Type	SCR Electric Heat
Capacity / FLA	30.0 kW / 37.7 FLA
Operation	Reheat/Heat
EAT / LAT	61.0°F / 67.3°F
EWT / LWT	N/A
GPM @ Ft Hd	N/A
Fluid	N/A
Face Area / Rows / FPI	N/A
Construction	Stainless Steel Elements
Control Valve	N/A
Control Valve Cv	N/A

Humidification Data

Type	Steam Canister
Steam Capacity / FLA	30 lb/hr / 10.7 FLA
Operation	Always Available

Unit Configuration & Airflow Patterns

- Downflow: Free or Ducted Top Return/Bottom Discharge
- Top Piping Connections
- Remote Free Discharge Split Condenser
- No Plenum Box
- 12" High Seismic Floor Stand

Refrigerant Field Connections

Indoor Unit (Qty 2 ea.) 3/4"OD Liq & 1 1/8" OD Discharge
Indoor HG Reheat N/A
Outdoor Unit (Qty 2 ea.) 3/4"OD Liq & 1 1/8" OD Discharge
Outdoor HG Reheat N/A

Connection Data

Condensate Drain 1/2" OD
Humidifier Supply 1/4" OD Copper
Hot Water N/A
Dual Cool N/A

Air Filtration Data

Filter Qty (4) 20x25x4 &
Qty (4) 16x25x4 (Merv 13)

Physical Data

Dimensions See attached cut sheet
Evap / Cond Weight 3120 lb / 1715 lb

Coil Coatings

- Supply Air Coils - No Coatings
- Condenser Coil - No Coatings

Factory Installed Optional Accessories

- Through-Door Main Power Disconnect (Evap Section) 65k SCCR
- Condensate Pump (48' Lift)
- Firestat
- Smoke Detector
- Fused Disconnect (Cond Section) 65 kA SCCR

Field Installed Optional Accessories

- Water Detector (Probe/Spot Type)
- Neoprene Vibration Isolators (Evap Section)
- Extra Filters (1 Set)

Control Type

- MC-Series Advanced Microprocessor w/ Alarms

Control Sequence

- MC-2000S RH Std DX Temp & Humidity Control

Sensors & Displays

- Unit Mtd Human Machine Interface (HMI)
- Wall Mounted Temperature & Humidity Sensor
- Duct Mounted OA Temperature Sensor
- Unit Mounted Return Air Temperature Sensor

Control Options

- BMS Card (BACnet MSTP)
- Multi-Unit Sequencing
- Airside Economizer - Dry Bulb + Enthalpy Control

Factory Warranties (Labor Not Included)

- 1 Year Limited Parts Warranty
- Extended 2 Year Control Board and Humidifier Warranty (Parts Only)
- 4 Year Extended Compressor Warranty

Select Standard Design Features

- Heavy Duty Gavanneal Steel Construction
- High Efficiency Scroll Compressor
- TXV with External Equilization
- High & Low Refrigerant Pressure Safety Switches
- Stainless Steel Drain Pan with Overflow Safety Switch
- Intertek (ETL) UL STD 1995 Listed/Labeled
- Factory installed and tested controls
- Each unit factory tested per UL 1995 Requirements

System Notes

1. System ships with a dry nitrogen charge.
2. Do not install refrigerant piping based upon connection sizes. Refrigerant piping runs must be sized according to piping requirements at www.aboveairioms.com.
3. Max total equivalent line length is 150 feet.
4. [Seismic construction on evaporator and condenser](#)

5. [Include 24V, 100VA transformer to power field provided damper.](#)

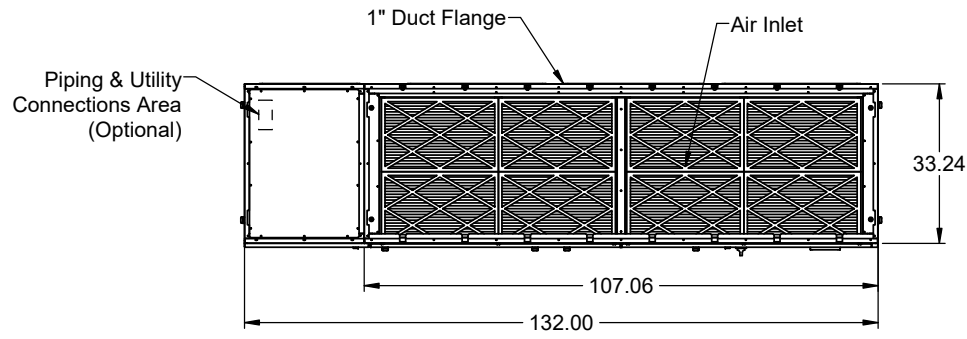

Top View

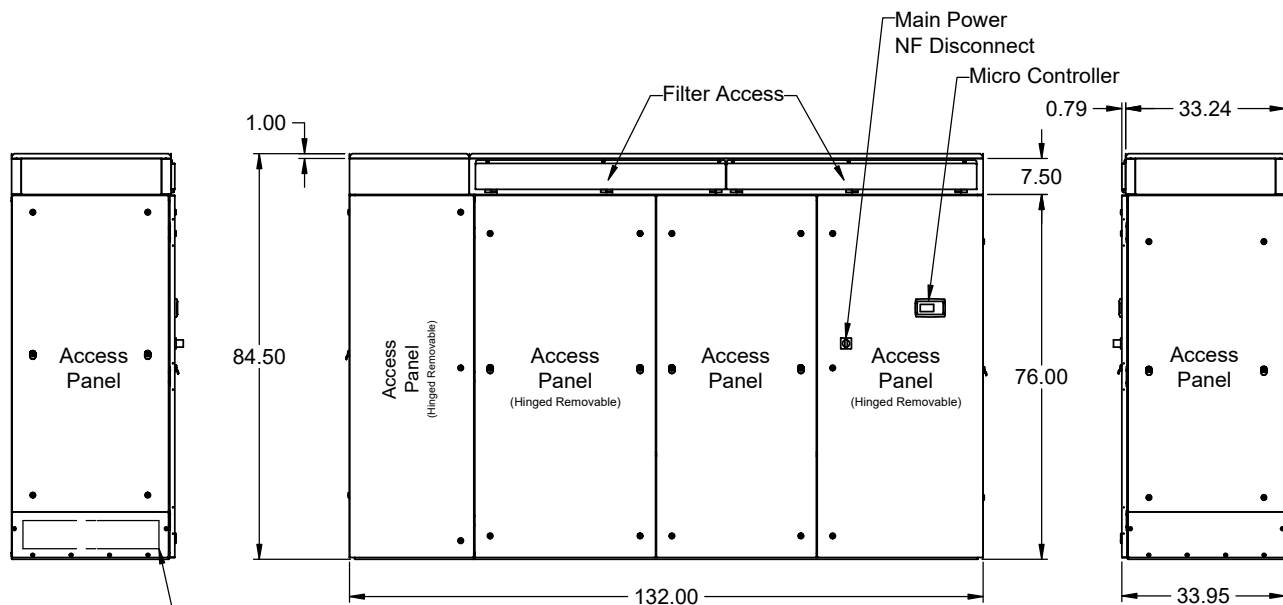
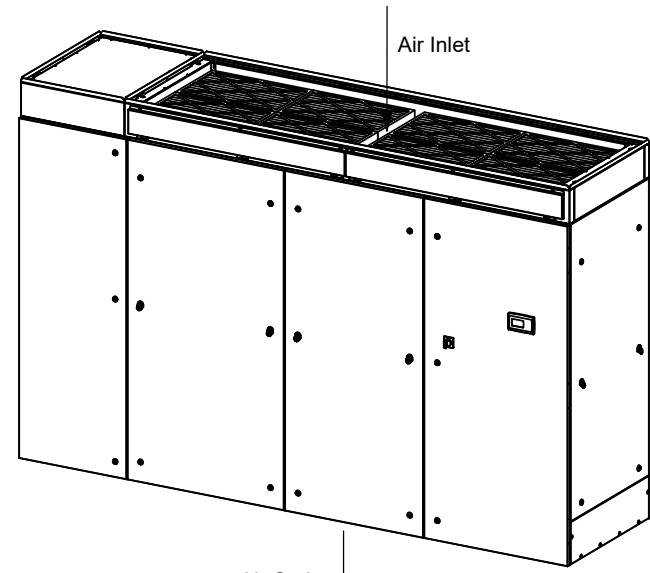

Left View

Front View

Right View

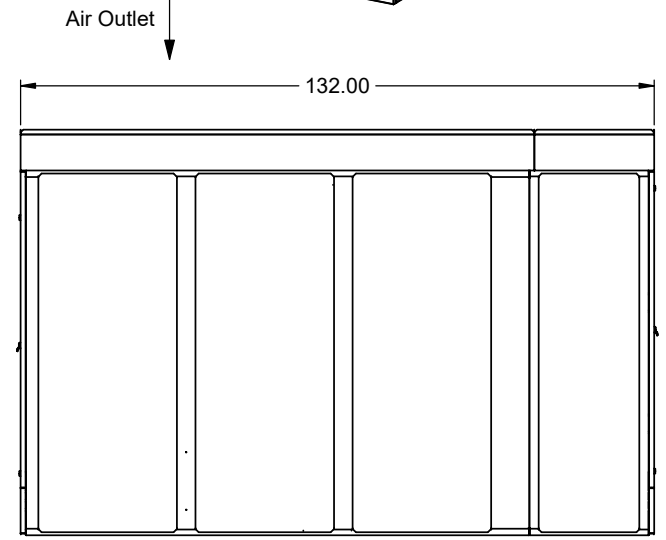

Rear View

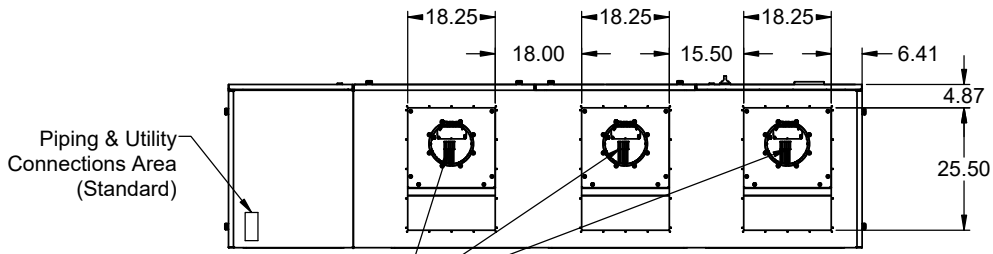

Bottom View

<p>Tel: (301) 874-1130</p>	Dwg No.	MD3413-2-V2-0001	
	Date	12/6/22	Rev B
Description			
MC2-DF-E Packaged BD V2			

REVISIONS							
ZONE	REV	DESCRIPTION	DATE	BY	CHKR	ENGR	APVD

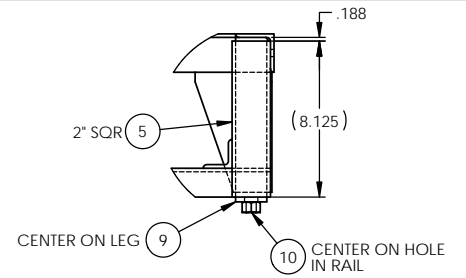
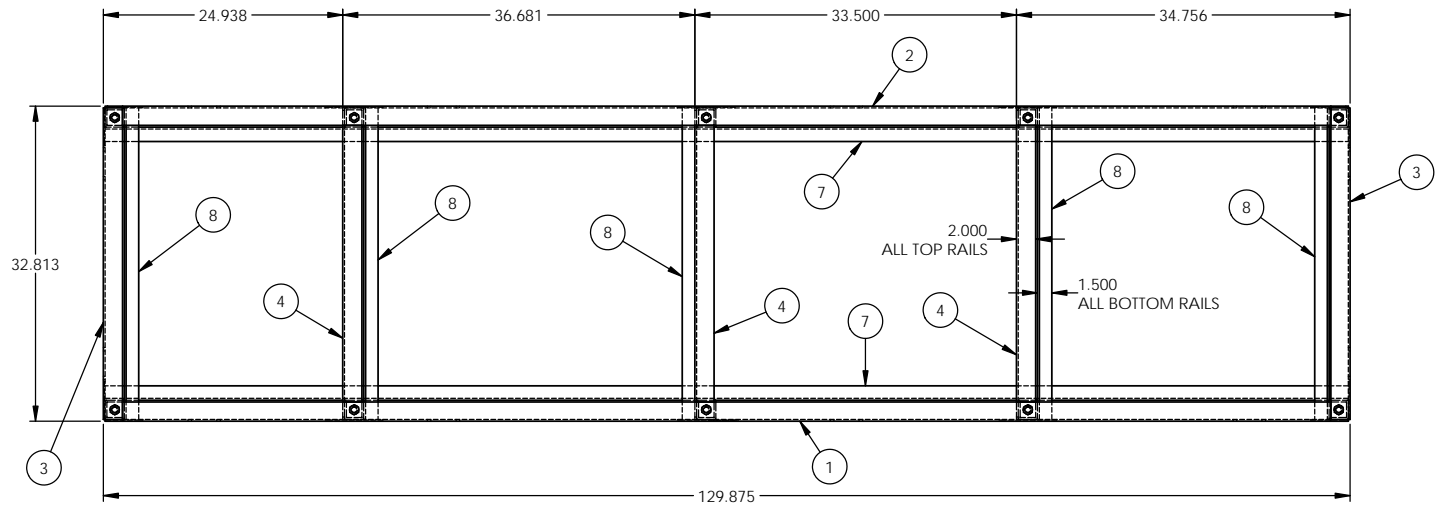

DETAIL A
SCALE 1 : 5
 TYPICAL (4) CORNERS
 FRONT RAIL & GUSSET HIDDEN FOR CLARITY

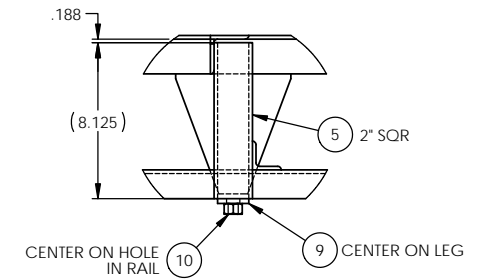

DETAIL B
SCALE 1 : 5
 TYPICAL (6) PLACES
 FRONT RAIL & GUSSET HIDDEN FOR CLARITY

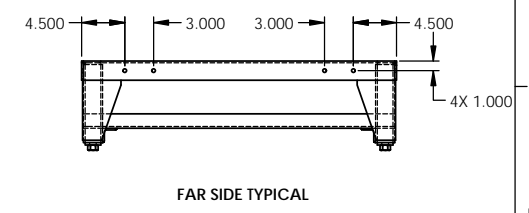
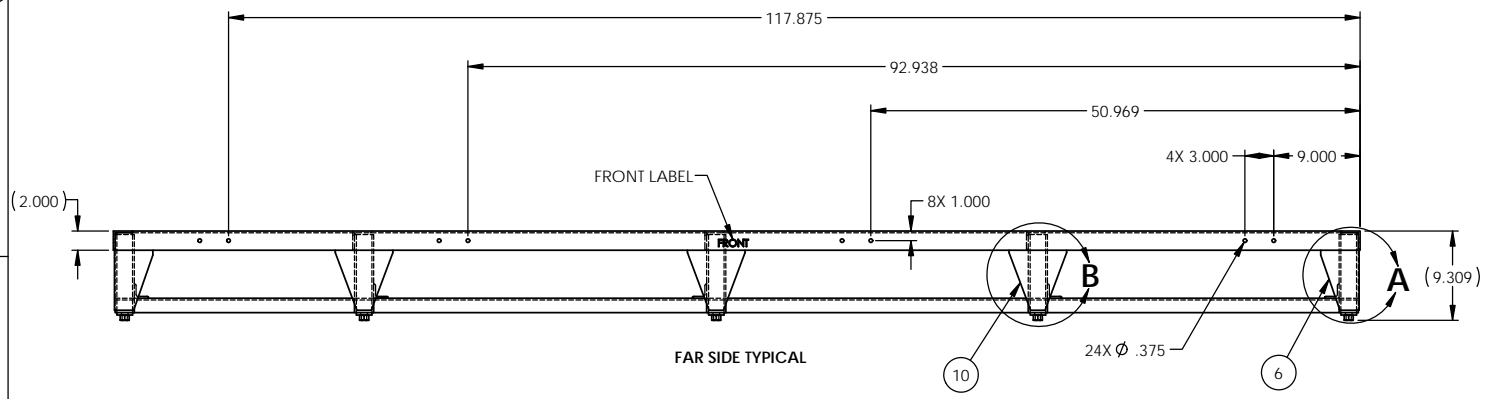

ITEM NO.	PART NUMBER	DESCRIPTION	QTY.
11	HNUT 0.6250-11-D-N	Nut, Hex 5/8-11	10
10	RL40233-2	Rail, Floor Stand Gusset Side 12" - MC2-E (Seismic)	6
9	RL40231	Rail, Nut - Universal (Seismic)	10
8	RL40230-2	Rail, Floor Stand Bottom Side Frame (Seismic) - MC2-E	5
7	RL40230-3	Rail, Floor Stand Bottom Front-Rear Frame Packaged (Seismic) - MC2-E	2
6	RL40229-2	Rail, Floor Stand Gusset Corner 12" (Seismic) - MC2-E	4
5	RL40228-5	Rail, Floor Stand Leg 12" (Seismic) - MC2-E	10
4	RL40227-4	Rail, Floor Stand Frame Center (Seismic) - MC2-E	3
3	RL40227-1	Rail, Floor Stand Frame Side (Seismic) - MC2-E	2
2	RL40227-6	Rail, Floor Stand Frame Rear Packaged (Seismic) - MC2-E	1
1	RL40227-5	Rail, Floor Stand Frame Front Packaged (Seismic) - MC2-E	1

NOTES:
 1. PAINT ALL SIDES AND EDGES.
 COVER NUT THREADS PRIOR TO PAINTING.

ARL1919-E-P-12
 MC2-E SEISMIC PACKAGED 12"

DIMENSIONS ARE IN INCHES TOLERANCES (UNLESS NOTED): HOLE SIZE: ± .005 HOLE TO EDGE: ± .010 HOLE TO HOLE: ± .010 HOLE TO FOLD: ± .015 FOLD TO FOLD: ± .015 ANGULAR: ± 1°						
AboveAir Technologies, LLC						
TITLE: Assembly, Floor Stand - MC2-E (Seismic)						
DRAWN YATES		DATE 8/23/23		SIZE C		DWG. NO. ARL1919
ENGR		MGR		SCALE: 1:10		REV -
ECN NO. ECN23C002				SHEET 5 OF 16		

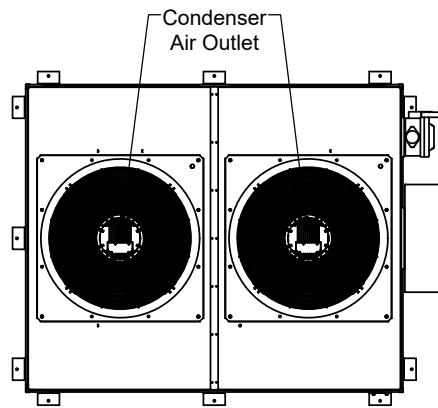

Top View

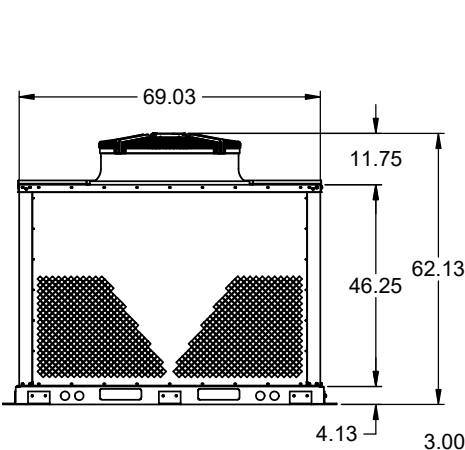
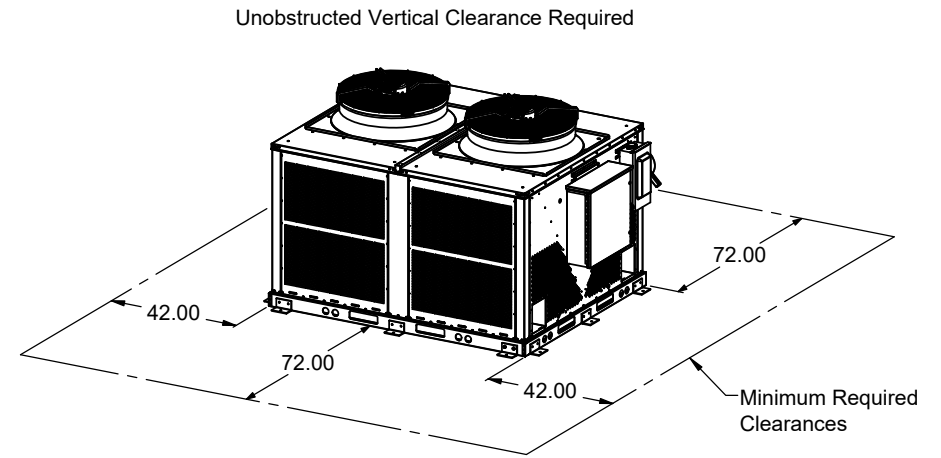

Left View

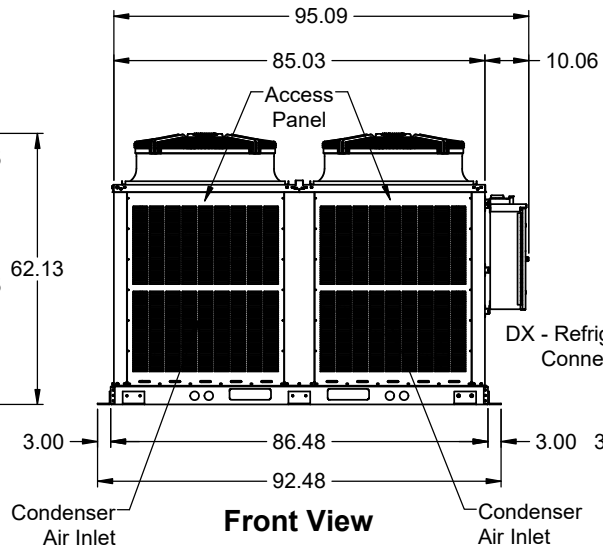

Front View

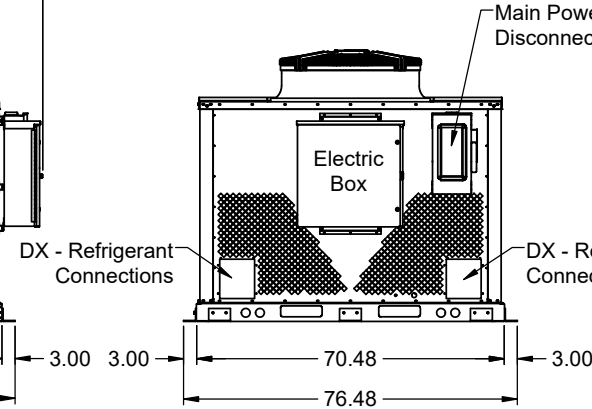

Right View

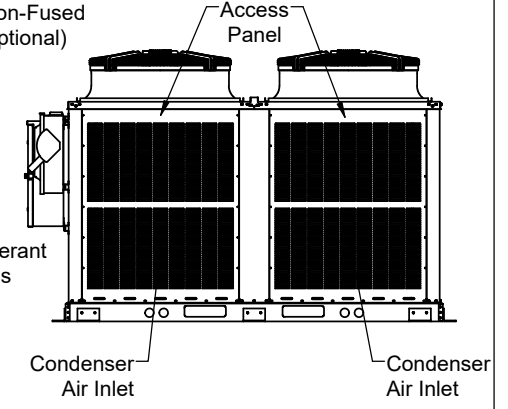

Rear View

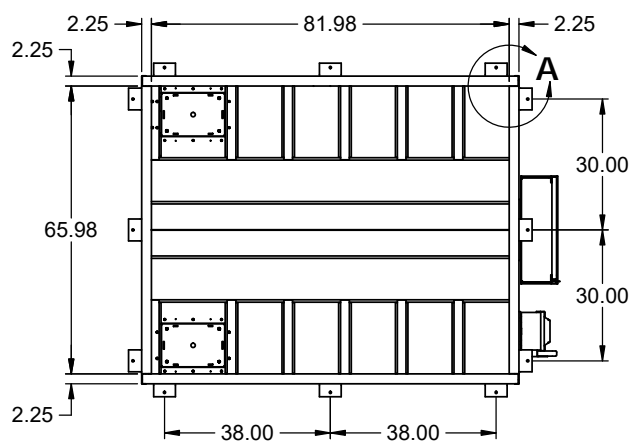

Bottom View

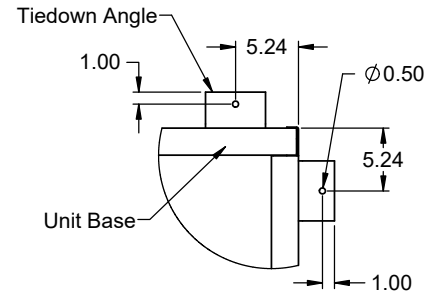

DETAIL A

(6) Places
Fasten To Unit With Supplied Hardware

	Dwg No.	MD3376-3-0001
	Date	8/21/24
Tel: (301) 874-1130	Rev	B
Description		
<p>XPU-XPX 25-30T (Dual Circuit) Twin EC Fans (Seismic)</p>		

MC-2000S RH Temperature & Humidity Control

The MC-2000S RH control sequence provides temperature and humidity control for a single zone. The outdoor air percentage should be no greater than 20%.

Unit Operation

Unit operation is initiated when all points are in their run positions.

System Enable: The system enable is controlled at the unit's display terminal, within the system enable menu.

Remote Stop/Start: Remote stop/start NC contacts are provided on all units and ship from the factory jumpered for continuous operation.

BMS Control: The unit is provided with an optional point that may be written by a BMS to index unit operation.

Schedule Control: The unit is provided with a local schedule that may be set to operate the unit in Occupied or Unoccupied modes based on its time clock.

Fan Control

When the unit is indexed for operation and in its occupied mode, the supply fan shall be energized after a 30 second delay (adj.) to allow for optional control damper actuation. The fan shall run continuously. After an additional 15 second delay (adj.) to allow for air proving, the unit shall operate as described herein.

Set Point Control (Optional): The system is provided with direct-drive, backwards inclined ECM impellers for balancing only. Fan will maintain a constant speed setting (100% output, adj.).

System Mode

The unit provides automatic change-over between cooling, heating, dehumidification, and humidification operation. The cooling and heating set points are separated by a dead band (5°F, adj.) to minimize unit cycling and prevent simultaneous cooling and heating. The dehumidification and humidification set points are also separated by a dead band (10%RH, adj.) to prevent simultaneous dehumidification and humidification operation.

Cooling Operation

On a rise in space temperature by 1°F above the cooling set point (75°F, adj.), the unit shall energize its first compressor stage. *The first compressor shall energize at 100% and*

modulate to meet the space set point (digital scrolls only). For dual circuit units, on a rise in space temperature by an additional 1°F, and a minimum delay of 3 minutes, the second compressor stage shall energize.

On a fall in space temperature, the second compressor stage (if applicable) shall de-energize. On a continued fall in space temperature, the first compressor stage shall be de-energized.

All compressors are subject to a minimum run time of 3 minutes and a minimum off time of 3 minutes to prevent short cycling.

Economizer (Air-Side Economizer, Optional)

If the outside air condition is below the economizer set point (69°F, adj.), the unit shall modulate the economizer dampers open. If the outdoor air temperature falls below 55°F (adj.), mechanical cooling shall be locked out and the dampers shall modulate to maintain 55°F into the unit.

On a fall in space temperature, the dampers shall return to their normal positions.

CO2 Damper Control (Optional): The economizer damper may also be set to respond to space CO2 level to provide demand control ventilation (<20% outdoor air). If the space CO2 level rises above the CO2 set point (700 ppm, adj.) by 50 ppm, the damper shall open to provide the unit's maximum outdoor air supply (<20%). On a fall in space CO2 level, the damper shall return to its minimum position. If both economizer and CO2 operation are required simultaneously, the damper shall open to satisfy the larger requirement.

Freecool (Water-Side Economizer, Water Cooled Only, Optional)

If the condenser water temperature is below the freecool set point (45°F, adj.), the unit shall energize its freecooling valve as its first stage of cooling in lieu of the first compressor stage. *The valve shall modulate to meet the space set point (modulating valves only).*

On a fall in space temperature, the freecool valve shall be de-energized.

On a continued rise in space temperature by 1°F and a minimum delay of 3 minutes, the freecool valve shall be de-energized and the unit shall sequence its mechanical cooling stages to meet the temperature requirement.

Dehumidification Operation

If the unit is not operating in its cooling or heating mode and on a rise in space humidity above set point (55%RH, adj.) by 1%RH, the unit shall enter its dehumidification mode. The unit shall energize its first compressor. *The first compressor shall energize at 100% and modulate to meet the space set point (digital scrolls only).*

On a fall in space humidity, the first compressor shall be de-energized.

Reheat Operation

When the unit is in its dehumidification mode, reheat is available. The hot gas reheat coil (if applicable) is the first stage of reheat. Additional heating stages (hot water, electric) may be enabled for reheat operation. Reheat stages shall energize to maintain the heating set point, as described under the Heating Operation section.

Heating Operation

On a fall in space temperature by 1°F below the heating set point (70°F, adj.), the unit shall energize its first heating stage. *The first heating stage shall modulate to meet the space set point (SCR or modulating valves only).* On a fall in space temperature by an additional 1°F, and a minimum delay of 3 minutes, the second heat stage shall energize.

On a rise in space temperature, the second heat stage (if applicable) shall de-energize. On a continued rise in space temperature, the first heat stage shall be de-energized.

Humidification Operation

If the unit is not in its cooling mode, on a fall in space humidity below the humidification set point (45%RH, adj.) by 1%RH, the humidifier shall be energized.

On a rise in space humidity, the humidifier shall be de-energized.

Head Pressure Control (Fan Cycling)

Condenser fan operation shall be controlled by a fan cycling switch. On a rise in system pressure above 275 psig, the condenser fan shall be energized. On a fall in system pressure below 210 psig, the condenser fan shall be de-energized.

Note: not available with digital scroll compressor option.

Head Pressure Control (Air-Cooled Units, ECM or VFD)

The condenser fan motor shall ramp up gently and operate continuously while the compressors are operating. The fan shall vary its speed to maintain the head pressure set point (325 psig, adj.), as controlled by the adjustable head pressure control PID loop.

Head Pressure Control (Air-Cooled Units, p266)

The condenser fan motor shall ramp up gently and operate continuously while the compressors are operating. The p266 controller shall vary the fan speed to maintain the head pressure set point.

Head Pressure Control (Flooded Head Pressure)

The unit is provided with a flooded head pressure control valve. On a rise in condensing pressure above 275 psig, the head pressure control valve opens to allow liquid refrigerant to flow from the condenser into the receiver. On a fall in condensing pressure, the valve modulates to bypass discharge gas around the condenser; this bypass causes the pressure at the outlet of the condenser to increase and the condenser floods with liquid refrigerant.

Note: not available with digital scroll compressor option.

Head Pressure Control (Water-Cooled Units, modulating valve)

On a call for compressor operation, the compressor start shall be delayed for 60 seconds (adj.) to allow the valve to fully open. After an initial modulation delay of 90 seconds (adj.), the valve shall modulate between its minimum and maximum operating positions based on the adjustable head pressure control PID loop and head pressure set point (325 psig, adj.).

Head Pressure Control (Water-Cooled Units, mechanical valve)

The unit is provided with a direct-acting pressure-actuated water control valve. On an increase in condenser pressure, the water control valve shall modulate towards its open position. On a decrease in condenser pressure, the valve shall modulate towards its closed position.

Note: not available with digital scroll compressor option.

Unoccupied Operation

If the unit utilizes the system schedule, then during unoccupied hours the fan shall be de-energized. If the space temperature falls below the unoccupied heat set point (60°F, adj.) by 1°F or rises above the unoccupied cooling set point

(80°F, adj.) by 1°F, the fan shall energize and the unit shall operate as described herein. On satisfaction of unoccupied set point, the unit shall de-energize the fan.

System Alarms

Air Proving: A differential pressure switch or current sensing switch (optional) closes to confirm airflow prior to the activation of other mechanical components. If the switch doesn't close after an adjustable time delay or opens during unit operation, the unit shall lock-out operation and enunciate an alarm.

Dirty Filter: An adjustable differential pressure switch shall open when the pressure drop across the filter exceeds the desired pressure drop and enunciates an alarm.

Condensate Alarm: A condensate pan switch, condensate pump overflow switch (optional), and water leak detector (optional) are connected in a NC series to detect high condensate. On a high condensate condition, the circuit will open and shut down all mechanical cooling or lock-out unit operation (optional) and enunciate an alarm.

High Refrigerant Pressure: The high refrigerant pressure (>600 psig, auto-reset) switch shall open on a high pressure condition and shut down compressor operation. If the switch resets, the system will attempt to restart the compressor up to 3 times in 10 minutes. If the switch does not reset within 90 seconds or on 3 failed start attempts, the system shall lock-out compressor operation, and enunciate an alarm.

Low Refrigerant Pressure: The low refrigerant pressure (<50 psig) shall open on a low pressure condition and after a time delay (90s, adjustable), shall lock-out compressor operation and enunciate an alarm.

Life Safety: A smoke detector (optional) and firestat (optional) or remote life safety system shall open a relay and break control power to the microprocessor. Unit operation shall cease. The Life Safety Alarm may optionally be routed through the controller to enunciate an alarm and signal the BMS.

Sensor Failure: If a sensor is reading out of range for 5 minutes, the unit shall enunciate an alarm to indicate an issue with the sensor.

High and Low Limit Alarms: Adjustable high and low limit alarms are user-adjustable for sensor points.

Waterflow Switch (Optional): A differential water pressure switch is factory installed on the water lines; if the differential pressure falls below the adjustable set point, compressor operation shall be locked out.

Sensor Installation Schematic

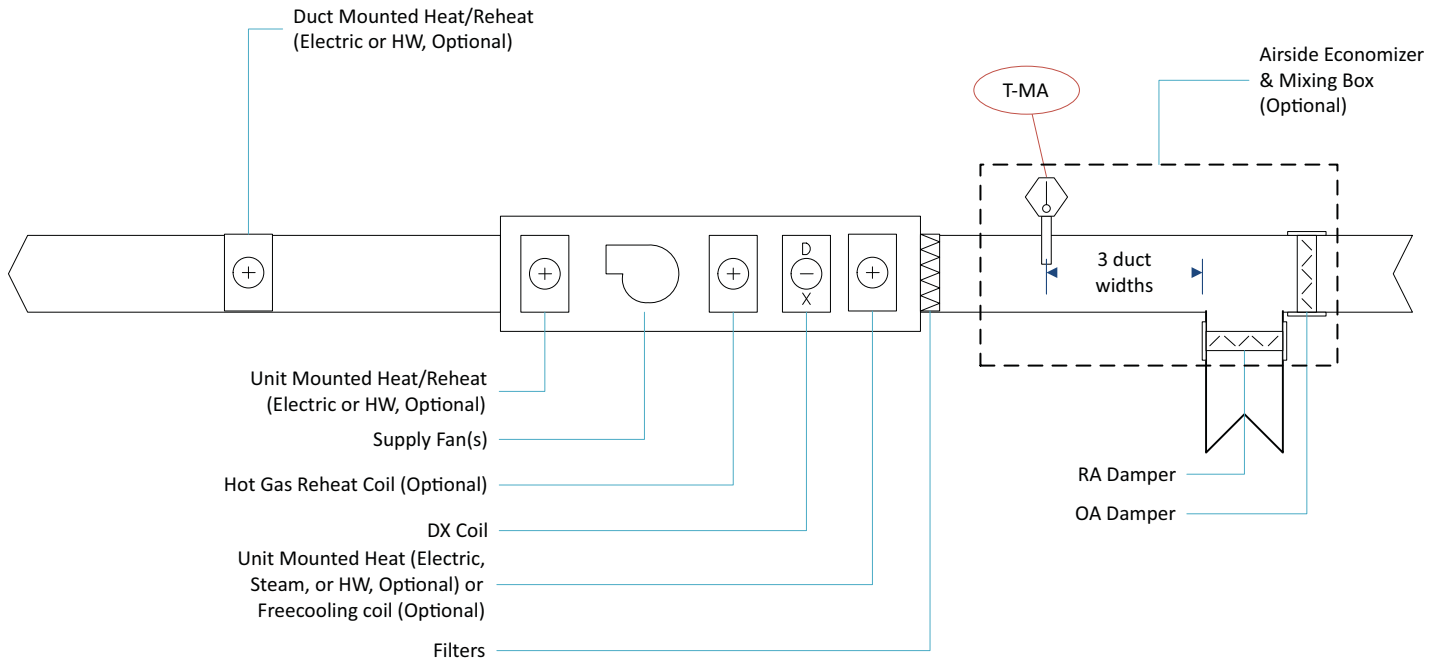

All sensors included with your unit must be installed prior to start-up or the unit will not operate. Sensors are typically either NTC type, 4-20mA, or 0-5 VDC.

Factory Installed Sensors

P-HEAD1(, 2) (Optional, Not Shown): The head pressure sensor(s) are factory installed on each circuit. Refer to piping diagrams for location detail.

TH-Return (MissionCritical and SpotCool Only, Not Shown): In lieu of a space mounted dry bulb temperature & humidity sensor, the sensor is factory mounted in the unit's return air section after the filters.

Display

Unit Display: All units are shipped with a display terminal and a 50 foot (standard) up to 200 foot cable for connection. The display terminal does not contain any sensors. It may be mounted in the space, mechanical room, or left in the electrical box. MissionCritical units ship with the display terminal cabinet-mounted. This terminal is required for unit operation.

Field Installed Sensors

TH-Space (Not Shown): A space mounted dry bulb temperature and humidity sensor is provided with the unit. The sensor should be mounted on an interior wall in the space away from all humidity and heat sources. Mount the sensor 60" AFF unless otherwise directed by the contract documents.

T-OA (Optional, Not Shown): An outdoor air dry bulb temperature sensor is provided when the air-side economizer option is purchased. This sensor must be installed in the outside air duct or plenum upstream of all air mixing.

T-MA (Optional): A mixed air dry bulb temperature sensor is provided when the air-side economizer option is purchased. This sensor must be installed downstream of the mixing box to control the OA and RA damper positions.

T-FC (Optional, Not Shown): A condenser water temperature sensor is provided when the freecooling option is purchased. This sensor must be mounted on the condenser water feed to the unit, upstream of any control valves so it senses the current condenser water temperature.

A-CO2 (Optional, Not Shown): If the unit is purchased with the CO2 control option, a space or duct-mounted CO2 sensor is provided with the unit for field mounting.



MC2-DX™ MissionCritical

*Vertical Floor Mounted A/C's
(Dual Circuit DX)*



Features & Benefits

- 21-105kW (6-30 Ton) Capacities
- DOE CCMS Compliant per AHRI Standard 1360 for Computer Room Air Conditioners
- DX Air, Water & Glycol Cooled Plus Free-Cooling Economizers
- Upflow & Downflow Air Patterns
- Fixed Speed w/ Hot Gas Bypass; Digital or 2-Spd Scroll Compressors
- Total Temp & Humidity Control
 - Free-Energy Hot Gas Reheat or Electric Reheat/Heat
 - Steam Humidifier
- 7/24/365 Low Ambient Head Pressure Control Options
- Microprocessor Controls & More!

21-105kW (6-30 Tons)
"Floor Mounted Precision A/C's"

AboveAir
TECHNOLOGIES

AboveAir™ MissionCritical™ vertical floor mounted precision air conditioners are the reliable environmental control solution to your precision cooling needs. Available in a wide variety of cooling methods and cabinet configurations including a full range of options, **AboveAir™** air conditioners are a step above!

- ☑ 100% Front-Access cabinet design
- ☑ Total Temperature & Humidity Control
- ☑ Up-Flow & Down-Flow air patterns
- ☑ Variety of cooling methods
- ☑ Self-contained & split systems
- ☑ Flexible options and accessories
- ☑ R410a Refrigerant
- ☑ Energy efficient operation

DX - Air Cooled, MCE & XPX-()

DX - Air Cooled Split with Propeller Fan, Outdoor Remote Condenser

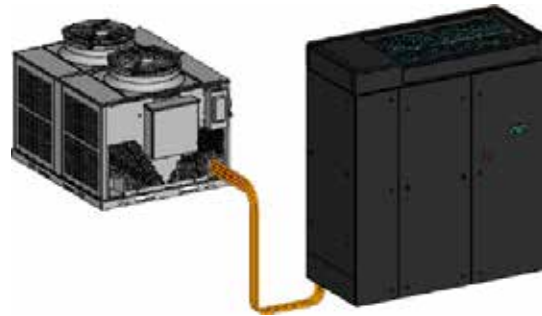

DX - Water Cooled, MCW-()

DX - Water Cooled Self-Contained (Optional Free-Cooling Economizers!)

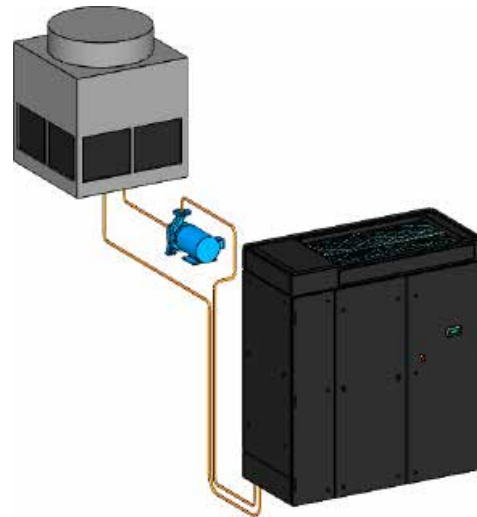

DX - Glycol Cooled, MCG-()

DX - Glycol Cooled Self-Contained Plus Glycol Drycoolers & Pump Packages (Optional Free-Cooling Economizers!)

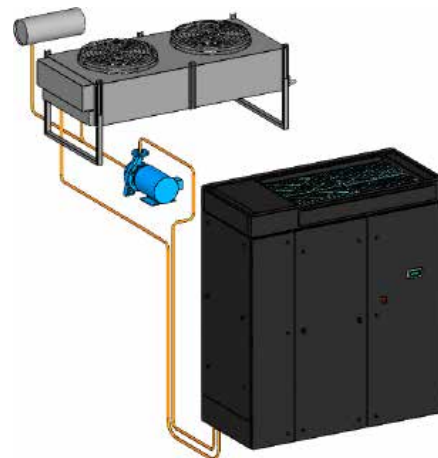

Contents

Introduction	2
Model Configurations	2
Features and Benefits	3
Model Nomenclature	4
Guide Specifications	5-9
DX - Cooling Capacity Data	10-12
Dual-Cool - Cooling Capacity Data	13
Free-Cooling - Cooling Capacity Data	14-15
Physical Data	16-17
Heat Rejection Data	18-19
Electrical Data	20-23
Typical Wiring Schematics	24-25
Recommended Service Clearance	26
Dimensional Data	27-31
Other AboveAir Products	Back Cover!

AboveAir™ MissionCritical™ precision A/C's are designed to meet your unique application dependent requirements. Select from a wide range of options and configurations:

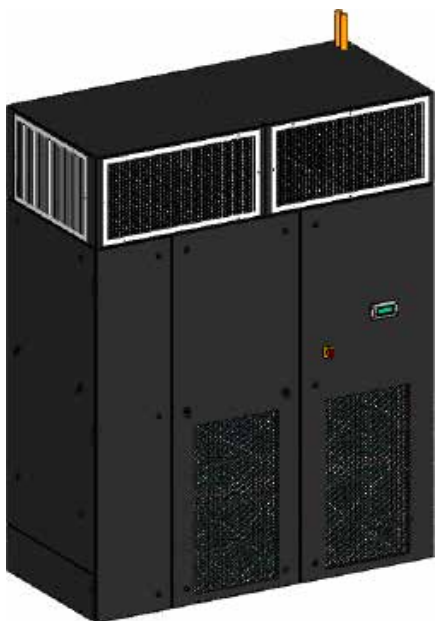

Up-Flow Air Pattern

**21-105kW
(6-30T)**
Dual Circuit DX



Down-Flow Air Pattern

Variety of Standard & Optional Features



Standard & Optional Features:

- MC-2000, Advanced Microprocessor Controls
- Electrode Steam Canister Humidifier
- Electric Reheat/Heat or Hot Gas Reheat
- Dual Scroll Compressors (Fixed, 2-Spd or Digital)
- EC Backward-Inclined Plug Fans
- Free-Cooling Economizer Coils
- High Efficiency Air Filtration (4" Merv-8, 11 or 13)
- Low Ambient Head Pressure Control
- 2 & 3-Way 350 psig Water / Glycol Cooled Head Pressure Control Regulating Valves
- Hot Gas Bypass
- Low Entering Condenser Water/Glycol Kit
- Top or Bottom Piping Connections

Accessories:

- 2 or 3-Way Plenum Discharge Boxes
- Floor Stands & Turning Vanes
- Condensate Pumps - Factory Installed
- Main Power Electrical Disconnects
- Firestats & Smoke Detectors
- Remote Water-Leak Detectors
- Condenser Water/Glycol Flow Switches
- Compressor Sound Jackets
- Glycol Pump Packages & Drycoolers
- ... and more!



Model Nomenclature

Packaged Systems & Split Evaporators

Split, DX - Remote Condensers & Condensing Units

MC	E - 070	D - 4 - 00	ER	H - EC - 00	- UF2	- C2 - D3
a	b - c	d - e - f	g	h - i - j	- k	- l - m

XPX	- 070	D - 4 - EC	- VF	1 - 00	- B
a	- b	c - d - e	- f	g - h	- i

- a: MC** - MissionCritical MC2 Vertical Floor A/C
- b: E** - DX, Split Evaporator (Compressor with Evaporator)
G - DX, Glycol Cooled - Packaged Self-Contained
W - DX, Water Cooled - Packaged Self-Contained
- c: 021** = 21kW (6.0T); **028** = 28kW (8.0T); **035** = 35kW (10.0T);
042 = 42kW (12.0T); **053** = 53kW (15.0T); **063** = 63kW (18.0T);
070 = 70kW (20.0T); **088** = 88kW (25.0T); **097** = 97kW (27.5T);
105 = 105kW (30.0T)
- d: D** - Dual Circuit DX System
- e: 1** - 208-230V / 1 Ph / 60 Hz
3 - 208-230V / 3 Ph / 60 Hz
4 - 460-480V / 3 Ph / 60 Hz
5 - 575V / 3 Ph / 60 Hz
7 - 277V / 1 Ph / 60 Hz
8 - 460-480V / 1 Ph / 60 Hz
- f: 00** - No Hot Gas Reheat
HG - Hot Gas Reheat (2-POS, On/Off)
MG - Hot Gas Reheat (Modulating 0-10Vdc)
HR - Hot Water Reheat/Heating Coil
SR - Steam Reheat/Heating Coil
- g: 00** - No Unit Mtd Electric Heat
EO - Electric Heat Only, No Reheat
ER - Electric Reheat/Heat
- h: 0** - No Humidifier
H - Electrode Canister Steam Humidifier
- i: EC** - EC = EC Plug Fan (Direct-Drive, Backward-Inclined Centrifugal Impeller, 0-10Vdc)
- j: 00** - No Economizer
DC - Dual-Cool / Alternate Water Source Coil
FE - Water/Glycol Side Free-Cooling Economizer Coil
- k: DFB** - Down-Flow Evap Air Pattern w/ Free or Ducted Top Return & Bottom Discharge to Raised Floor
DFE - Down-Flow Evap Air Pattern w/ Free or Ducted Top Return & Front Free-Discharge to Floor Level
UF0 - Up-Flow Evap Air Pattern w/ Front Free-Return & Top Ducted Discharge
UF1 - Up-Flow Evap Air Pattern w/ Front Free-Return & Top 1-Way Plenum Discharge Box
UF2 - Up-Flow Evap Air Pattern w/ Front Free-Return & Top 2-Way Plenum Discharge Box
UF3 - Up-Flow Evap Air Pattern w/ Front Free-Return & Top 3-Way Plenum Discharge Box
UFR - Up-Flow Evap Air Pattern w/ Rear Ducted or Free-Return & Top Ducted Discharge
- l: C2** - MC2 Cabinet Size ... A2 = 21-35kW (6-10T); B2 = 42-53kW (12-15T); C2 = 63-70kW (18-20T); D2 = 88kW (25T); E2 = 97-105kW (27.5-30T)
- m: D1** - Dual Scroll Compressors - 1st Circuit Fixed Spd w/ Hot Gas Bypass; 2nd Circuit Fixed Spd
D3 - Dual Scroll Compressors - 1st Circuit Digital; 2nd Circuit Fixed Spd
D6 - Dual Scroll Compressors - 1st Circuit 2-Spd; 2nd Circuit Fixed Speed

- a: VCX** - DX, Split Indoor Vertical Floor Mtd Remote Air Cooled Centrifugal Blower Condenser (Compr Located w/ MCE Evap)
XCX - DX, Split Indoor Ceiling Mtd Remote Air Cooled Centrifugal Blower Condenser (Compr Located w/ MCE Evap)
XPX - DX, Split Outdoor Mtd Remote Air Cooled Propeller Fan Condenser, (Compr Located w/ MCE Evap)
- c: 021** = 21kW (6.0T); **028** = 28kW (8.0T); **035** = 35kW (10.0T);
042 = 42kW (12.0T); **053** = 53kW (15.0T); **063** = 63kW (18.0T);
070 = 70kW (20.0T); **088** = 88kW (25.0T); **097** = 97kW (27.5T);
105 = 105kW (30.0T)
- d: D** - Dual Circuit DX System
- d: 1** - 208-230V / 1 Ph / 60 Hz
3 - 208-230V / 3 Ph / 60 Hz
4 - 460-480V / 3 Ph / 60 Hz
5 - 575V / 3 Ph / 60 Hz
7 - 277V / 1 Ph / 60 Hz
8 - 460-480V / 1 Ph / 60 Hz
- e: 00** - N/A
AA - Axial Fan w/ Std Motor
AB - DWDI FC BD Blower w/ ODP Motor
EA - Axial Fan w/ ECM
EC - EC DD Backward-Inclined Impeller
- f: 00** - Not Applicable
LD - Ducted, 90 Degree / Right-Angle, In-Front / Out Left-Side
MI - Ducted, Mirror-Image Same-Face Condenser Air Pattern
RD - Ducted, 90 Degree / Right-Angle, In-Rear / Out Right-Side
SF - Ducted, Same Face Condenser Air Pattern
ST - Ducted, Straight-Thru (ZST) Condenser Air Pattern
VF - Free Airflow, Vertical Discharge Air Pattern
- g: 0** - Not Applicable
1 - Slab or Wrap Around Type
- - Cabinet Size ... VCX-B, C, D, E or F & XCX-B, C or D
- h: 00** - No Compressor in this section (DX Condenser Model)
- i: 0** - No Head Pressure Control
A - Low Amb Fan Cycling Head Pressure Control
B - Low Amb Variable Speed Fan Head Pressure Control
C - Low Amb Flooded Head Pressure Control
D - Water/Glycol Regulating Valve - 2-Way, 150 psig
E - Water/Glycol Regulating Valve - 2-Way, 350 psig
F - Water/Glycol Regulating Valve - 3-Way, 150 psig
G - Water/Glycol Regulating Valve - 3-Way, 350 psig

General

Summary



These specifications describe the requirements for a vertical floor mounted packaged (or split) precision air conditioner. The system shall be designed to control space temperature and humidity.

The air conditioning manufacturer shall design and furnish all equipment in the quantities and configurations shown on the project plans and specifications.

The system shall be provided by AboveAir Technologies in Frederick, Maryland, USA. The system shall be listed by Intertek (ETL Semko), Inc. to conform with UL Std 1995 and be certified to CAN/CSA Std C22.2 No. 236 (Control No. 3091370). The system shall be NYC MEA229-06-E and Chicago Code Approved. The system model number shall be _____.

Design Requirements

The system shall be an AboveAir Technologies MissionCritical™ brand, factory assembled and tested. The system shall be designed for indoor installation.

The system shall have a total cooling capacity of _____ BTU/H, and a sensible cooling capacity of _____ BTU/H, based on an entering air condition of _____ °F DB, and _____ °F WB, _____ % RH.

The evaporator section shall be designed for _____ Volt, _____ Phase, _____ Hertz main power supply. The remote condensing unit section (if applicable) shall be designed for _____ Volt, _____ Phase, _____ Hertz main power supply.

Submittals

Submittals shall be provided after manufacturer's receipt of a written purchase order and shall include: Detailed Performance and Electrical Data; Guide Specifications; and Dimensional Drawings.

Quality Assurance

The system shall be factory run tested prior to shipment. Testing shall include, but shall not be limited to: "HiPot" Test (2 times rated voltage plus 1000 volts, per UL 1995 testing requirements). The system shall be designed and manufactured according to world class quality standards.

Products

Standard Features

Cabinet

The cabinet chassis and access panels shall be powder-coat painted heavy gauge galvanized steel for decor matching and corrosion resistance. Cabinet access panels shall rest in recessed pockets designed for minimum air leakage. The cabinet and access panels shall be lined with 2 lb/ft² high density sound and thermal insulation and sealed with self-extinguishing gasketing conforming to NFPA 90A and 90B.

Component Access

The unit shall be serviceable through front and side (as required) access panels with quick-release quarter-turn fasteners.

Electrical System

General:

The electrical system shall conform to National Electric Code (NEC) requirements according to UL 1995. The control circuit shall be a 24 VAC low voltage circuit.

The electrical system shall include, but not be limited to the following factory installed items: main power distribution block; grounding lug; 24 VAC control transformer; terminal connections; and motor controllers with start protection and circuit breakers for blower motors, compressors and each electric heater stage (if applicable).

Split DX Systems: (separate power) Split systems shall require separate main power supplies to the evaporator and condensing unit sections. The evaporator and condensing unit sections shall be electrically interlocked by a field wired 24 volt control signal.

Overflow Safety Float Switch:

The system shall be provided with a factory installed float type condensate overflow safety switch. The circuit shall

be designed to shut down all system water producing operations in the event of an overflow condition.

Main Power, Disconnect (MC_ Evap Section)



The indoor evaporator section shall be provided with a factory installed main power non-fused disconnect. The disconnect shall be NEMA rated for indoor or outdoor installation as required.

Air Distribution

Evap Blower/Motor

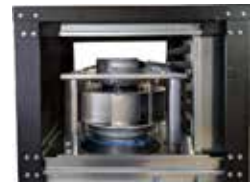

The evaporator blower assembly shall be a backward-inclined direct-drive centrifugal impeller with variable speed EC (electronically commutated) motor. The blower shall be designed for _____ CFM @ _____ inches external static pressure (e.s.p.)

Variety of Air Patterns



Down-Flow (DF)

Down-Flow Air Pattern:

DFF: Bottom Disch Into Raised Floor

The system shall be configured for down-flow evaporator air pattern with top free or ducted return and bottom discharge into raised floor. (Refer to Floor Stand Options.)

Air Filtration



The return air filters shall be 4 inch thick pleated and Merv-8 efficiency rated (based on ASHRAE 52.2). The filters shall be serviceable without shutting down the system.

Piping Connection Location

- Bottom Piping Connections

Direct Expansion Systems

DX - Evaporator Coil



The DX evaporator coil shall be constructed of copper tubes and aluminum fins. The system shall be designed for a draw-through air pattern for maximum heat transfer. Coil end-plates shall be hot dipped galvanized. The evaporator coil shall be mounted in an insulated stainless steel condensate drain pan.

Dual Scroll Compressors



Each compressor shall be the high efficiency, low sound Scroll type mounted on vibration isolators and located in a separate compartment out of the evaporator air stream to facilitate servicing while equipment is operating. Each compressor shall be complete with reversible positive oil pump, charging and service ports, internal spring isolation, and discharge gas vibration eliminator.

DX - Refrigeration Circuit



Each refrigeration circuit shall be pre-piped with type "L" refrigerant copper tubing. The refrigeration system shall include but not be limited to: expansion valve with external equalizer and rapid bleed-through capacity. Features shall include filter dryer, sight glass, pressure fittings and high pressure/low pressure safety cutouts.

Cooling Configurations

DX - Air Cooled Split

(Split Evap & Outdoor Remote Condenser)
MCE-() & XPX-()

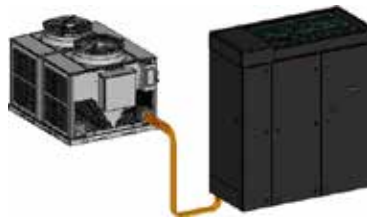

The system shall be a split configuration with compact indoor vertical floor mounted dx evaporator precision air conditioner with outdoor dx air cooled propeller fan remote condenser. The compressor shall be located in the indoor evaporator section. The condenser shall be sized for full heat of rejection at 95°F ambient and be capable of operation to ___ °F low ambient air temperature.

The system shall be refrigerant charged and run tested at the factory prior to shipment. The evaporator and condenser sections shall ship separately with a dry-nitrogen charge ready for field refrigerant charging.

Options

DX Air Cooled Condenser - Low Ambient Control

-20°F Ambient - Variable Spd Fan (XP* & XPU Models)

Variable fan speed head pressure controls (JCI P266 or Modulating EC) shall be factory installed to allow for low ambient operation to -20°F. Compressor cold start time delay relay and crankcase heater shall be factory installed with the -20°F low ambient control feature.

CONTROL OPTIONS

MC-2000™, Advanced Temp/Humid Microprocessor Controller w/ Alarms & BMS Connection



The system shall be provided with a MC-2000™ advanced microprocessor based temperature and humidity controller with alarms.

Select Features/Benefits:

- 4x20 Character Liquid Crystal Alpha-numerical Display
- User Configurable
- Run-Time Hours
- Current Unit Mode Status
- Alarm Status
- Digital & Analog Inputs / Outputs
- Temperature Anticipation
- Remote Stop / Start Contact
- Summary Alarm Contact
- Automatic or Manual (selectable) Restart After Power Loss
- Sequential Load After Restart
- Recovery Delay
- Compressor Short Cycle Timers
- Cold Start Time Delay
- Security Password Access
- Self-Diagnostics
- Service Mode

Unit Status Display

The control system shall display current unit functions and room status (if applicable):

- Current Dry Bulb Temp Set Point
- Current Relative Humidity Set Point
- System ON/OFF
- Cooling
- Heating
- Humidifying
- Dehumidifying
- Reheating
- Actual Room DB Temperature
- Actual Room Relative Humidity

Alarm Conditions:

Alarm conditions activate an audible and visual indicator plus close a summary alarm dry contact connection. The control system shall alert to the following alarm conditions (if applicable):

- High Temperature
- Low Temperature
- High Humidity
- Low Humidity
- Sensor Failure
- Summary Failure
- Loss of Air Flow
- High Head Press
- Smoke Detection
- Firestat
- Leak Detection
- Loss of Power
- Dirty Filter
- Loss of Fluid Flow

Digital & Analog Control Inputs / Outputs:

The control system shall be capable of both digital (ON/OFF) and analog (proportional integral, PI) input and output control.

Select MC-2000 Options:

- Multi-Unit N+1 Sequencing
- BMS Communications Interface:
 - BACnet over MS/TP (RS485 Serial)

Heat / Reheat Options

Electric Reheat/Heat



An electric heating system shall be factory installed to provide:

- Electric Heat Only during heat mode
- Electric Reheat to offset sensible cooling during the dehumidification mode and to provide heating during heat mode.

Heater elements shall be the low-watt density finned-tubular type. The heater shall be complete with individual heater stage starter/contactors and overheat safeties. Systems incorporating factory installed electric heaters shall require only single point power to the main unit power distribution. The electric heat shall have a capacity of _____ BTU/H and a KW rating of ___ KW, controlled in ___ stages.

Humidification Options

Steam Humidification



An electrode steam canister type humidification system shall be factory installed within the air conditioning system. The humidifier shall be complete with disposable canister, steam distributor, fill and drain valve, air gap, automatic flush cycle, manual humidity output adjustment and field installed remote wall mounted humidistat. The humidifier shall have a maximum output capacity of _____ lbs/hr.

Accessories

Floor Stand



A _____ inch nominal high (___ in to ___ in adj. range) floor stand shall be factory provided for field installation. The floor stand shall have adjustable legs with vibration isolation.

Condensate Pump

(Factory Installed - Both UF & DF!)



A condensate pump shall be factory provided and installed within the indoor evaporator section (*Up-Flow & Down-Flow Air Pattern Configurations*). The condensate pump shall be provided with dual internal float switches: one for pump operation initiation and the other for pump reservoir overflow safety.

Main Power, Non-Fused Disconnect

(Remote Condenser Section)



The remote condenser shall be factory provided with a main power non-fused disconnect for field installation. The disconnect shall be NEMA rated for indoor or outdoor installation as required.

Remote Water-Leak Detector



A remote water-leak detector shall be factory provided for field installation. The remote water-leak detector shall be wired to shut down all A/C unit water producing functions upon sensing a water leak.

Smoke Detector

(Factory Installed)



A Smoke Detector shall be factory installed in the return air stream of the unit and wired to the A/C unit electrical control panel. The Smoke Detector shall shut-down all A/C system operations upon activation.

Firestat

(Factory Installed)



A Firestat shall be factory installed in the return air stream of the unit and wired to the A/C unit electrical control panel. The Firestat shall shut-down all A/C system operations upon sensing a high return air temperature condition.

Mounting Vibration Isolators

Floor Mounted Isolators:

Each indoor vertical floor mounted section shall be provided with a set of quantity four vibration mounting isolators with non-skid neoprene acoustical isolation pads.

Innovative HVAC Solutions

MissionCritical Units - Precision A/C's



**SC-2x4 SpotCool
Ceiling Mounted A/C's**
(4-11kW, 1-3 Tons)



**HK Horizontal Ducted
Ceiling Mounted A/C's**
(4-70kW, 1-20 Tons)



**MC Vertical Floor Mtd A/C's
Up-Flow & Down-Flow**
(4-1080kW, 1-307 Tons)



**WC Wall-Cassette and
FC Floor-Console Mtd A/C's**
(4-18kW, 1-5 Tons)

Outdoor-Air Units - IAQ High Percent (20%-100% OA)



HK-OA Horizontal Ceiling Mtd
(1-30 Tons)



VK-OA Vertical Floor Mtd
(1-50 Tons)

Specialty Units - A/C's & Water Source Heat Pumps



**SC-2x4 SpotCool
Ceiling Mtd A/C's**
(4-11kW, 1-3 Tons)



**HK Horizontal Packaged
& Split Ceiling Mtd A/C's**
(4-70kW, 1-20 Tons)



**VK Vertical Packaged &
Split Floor Mtd A/C's**
(4-105kW, 1-30 Tons)

Remote Heat Rejection Units

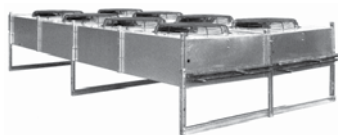

**Remote Air Cooled
Condensers, Condensing Units &
Glycol Drycoolers**

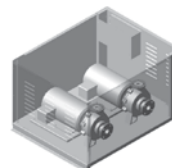

**Single, Dual & Triplex
Glycol Pump Packages**
(1/2 to 50 HP, VFD Optional)

A25 Series Warm Air Control with Manual Reset

The A25 Series Warm Air Control with Manual Reset is designed to shut down fans, burners, dampers, etc., when the temperature of the sensed air becomes greater than the controller's setpoint.

When the sensed temperature increases to the controller's setpoint, the A25's switch will open. Manual reset is required to reclose the electrical circuit. The A25 may be used as a high limit control in the supply air duct (or plenum) where a lockout type control is desired or required by local code.



Figure 1: The A25 Series Warm Air Control with Manual Reset

Features and Benefits	
<input type="checkbox"/> Trip-free Reset Lever	Does not allow the reset switch to hold the contacts in a closed (on) position
<input type="checkbox"/> Pilot Duty Electrical Rating for up to 600 Volts Maximum	Allows direct control of high voltage motor starters
<input type="checkbox"/> Enclosed Switch	Protects switch contacts from dust
<input type="checkbox"/> Rod and Tube Sensing Element	Provides maximum response and allows for a high maximum sensing element temperature
<input type="checkbox"/> Adjustable Duct Mounting Flange	Controls the depth of sensor insertion into the airstream; compensates for insulation depth
<input type="checkbox"/> Wide Temperature Range	Allows the A25 to be used with many applications

Application Overview

A typical application for the A25 Series Warm Air Control with Manual Reset is to stop the operation of air conditioning or ventilating fans upon a temperature rise. Models A25AP and A25CP are Factory Mutual approved for use as fire protection devices.

Installation

1. Select a mounting location for the A25 in the duct (or plenum). The location must allow the sensing element to sense the average temperature in the duct.
2. Drill (or cut) a 1-3/8 in. hole in the duct at the selected mounting location (refer to Figure 2).

3. Using the flange as a template on the duct, mark the location for two 1/2 in. (13 mm) No. 10 sheet metal screws.
4. Punch (or drill) both sheet metal screw holes in the duct at the marked locations.
5. Secure the flange to the duct with two 1/2 in. (13 mm) No. 10 sheet metal screws provided.
6. Insert the sensing element and sleeve through the flange installed in Step 5 (and into the duct).
7. Secure the A25 to the flange by screwing the set screw firmly against the sleeve. Do not overtorque the set screw.

Note: Insert the sensing element as far as possible into the air stream without allowing it to contact any object inside the duct. Provide at least 5-3/4 in. (14 cm) clearance between the sensor and any other objects inside the duct.

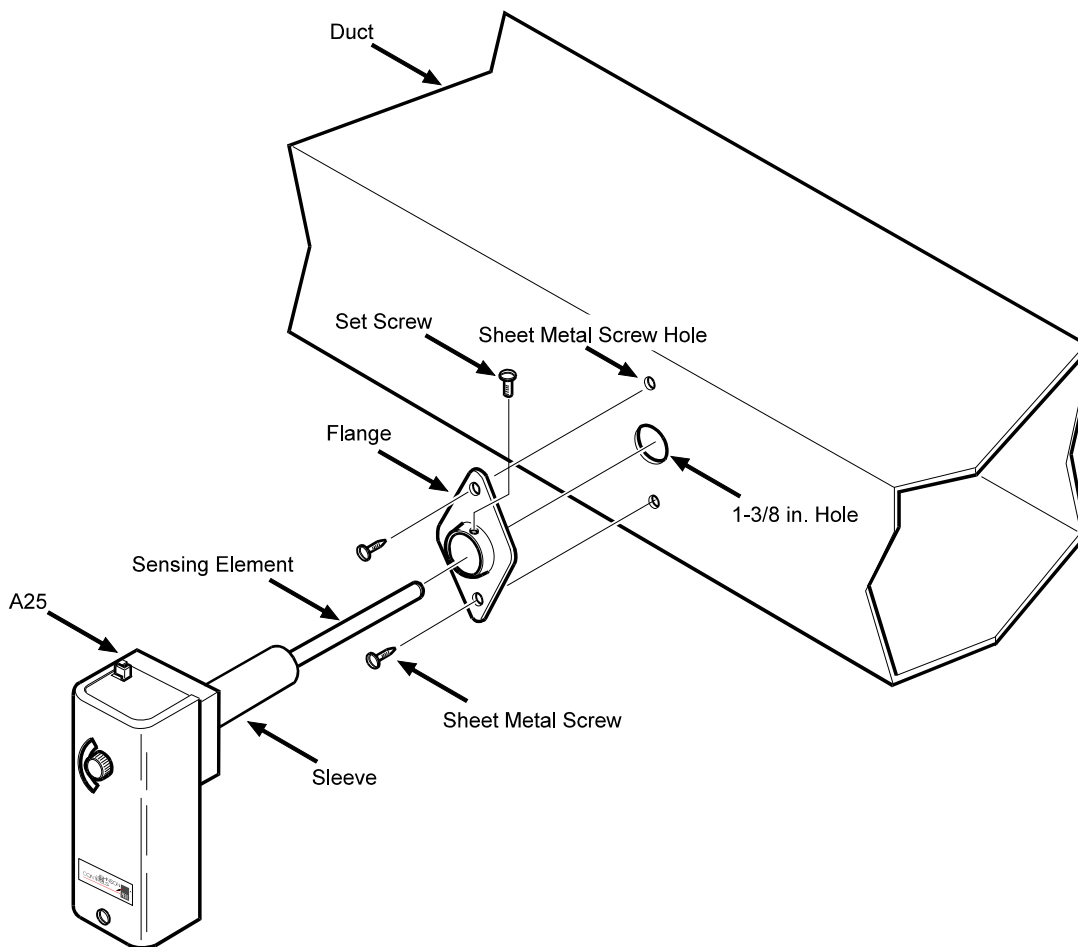

Figure 2: Installing the A25

Wiring



WARNING: Shock hazard. To avoid electrical shock or damage to equipment, disconnect all power before making wiring connections.

IMPORTANT: Only use the terminal screws furnished with the A25 (8-32 x 1/4 in. binder head). Use of other screws will void warranty, may damage switch terminals, and result in improper connections.

If available, follow the instructions for the unit onto which the A25 will be installed. Make all wiring connections only with copper conductors and in accordance with the National Electrical Code and local regulations. Refer to the label inside the A25's cover for the maximum electrical rating.

Models A25CN and A25CP SPDT (Single Pole Double Throw) Units

The wiring terminals on the SPDT (Single Pole Double Throw) models are color coded:

- Red is common.
- The red to yellow circuit closes on temperature increase.
- The red to blue circuit opens on temperature increase.

Refer to Figures 3 and 4 for terminal identification and typical wiring connections.

When the reset lever is pressed during normal operation, the trip free contacts are activated, the red to blue contact opens and the auxiliary red to yellow contact closes. At this point, the auxiliary system will activate.

Models A25AN and A25AP SPST (Single Pole Single Throw) Units

When the temperature increases to above the setpoint, the circuit opens. When the reset lever is pressed after the sensed temperature decreases to approximately 20F° (11C°) below the setpoint, the circuit closes.

Refer to Figures 5 and 6 for terminal identification and typical wiring connections.

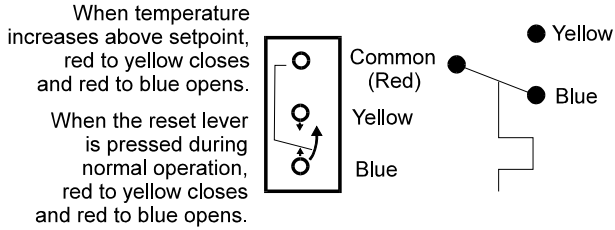

Figure 3: Terminal Identification for A25CN and A25CP SPDT Models

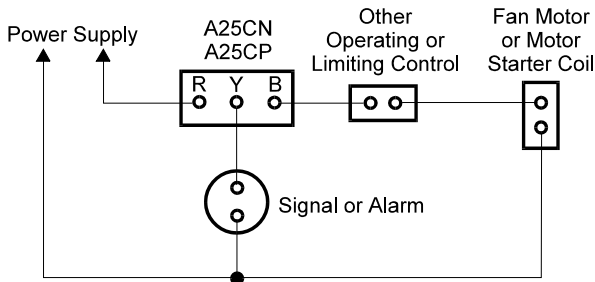

Figure 4: Typical Wiring Diagram of A25CN and A25CP SPDT Models

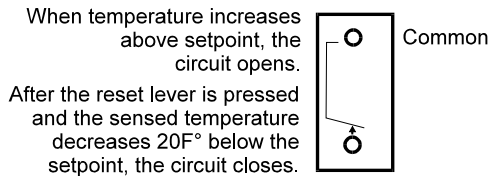

Figure 5: Terminal Identification for A25AN and A25AP SPST Models

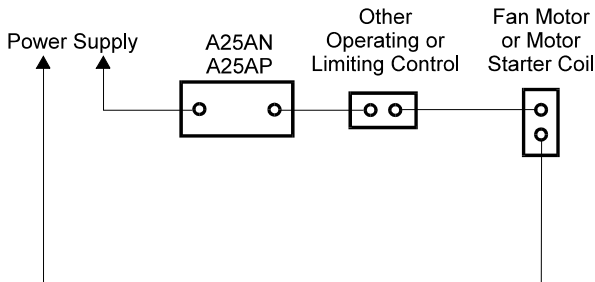

Figure 6: Typical Wiring Diagram for A25AN and A25AP SPST Models

Checkout Procedure

After installing the A25, perform the following procedures. Observe at least three complete operating cycles to verify that all components are functioning properly. If the unit fails to checkout, refer to the troubleshooting chart (Table 2). Do not attempt to make adjustments.

Return Air Applications

1. After completing the installation and wiring procedures, turn on the power to the circuit.
2. Turn the setpoint knob counterclockwise until the A25 shuts down the system.

The A25 should lockout and the alarm or signal (if applicable) should activate.

Note: The setpoint at shutdown should equal the approximate duct air temperature.

3. Turn the setpoint knob clockwise to the desired setpoint.

Nothing should happen.

4. Press the reset lever.

The system should restart and the alarm or signal (if applicable) should shut off.

Supply Air Applications

1. After completing the installation and wiring procedures, turn on the power to the circuit.
2. Raise the supply air temperature to the setpoint temperature.

Note: The supply air temperature can be raised by simulating a fan failure or restricting the return air flow.

3. When the system shuts down, determine the temperature at the A25 sensing element.

The temperature reading should closely approximate the A25's setpoint at which the system is shut down and (if applicable) the alarm or signal is activated.

4. Return the system to normal operation by re-establishing air flow or by restarting the fan.

5. Press the reset lever.

The system should restart and the alarm or signal (if applicable) should shut off.

Operation

Models A25AN and A25CN

Setpoint Adjustment: Adjust the A25 setpoint by rotating the setpoint knob (Figure 7). The setpoint is displayed in the setpoint window.

Test Procedure:

To test (trip) the A25: Raise the temperature at the sensor above the setpoint or lower the setpoint below the ambient temperature. *The control should lockout (trip).*

To reset after test: Lower the temperature at the sensor to 20F° (11C°) below the setpoint or raise the setpoint to 20F° (11C°) above the ambient temperature. Press the reset lever. The A25 should reset (closing the circuit).

Reset Procedure: Verify that the temperature has dropped to 20F° (11C°) below setpoint. Press the reset lever to reset the A25 (closing the circuit).

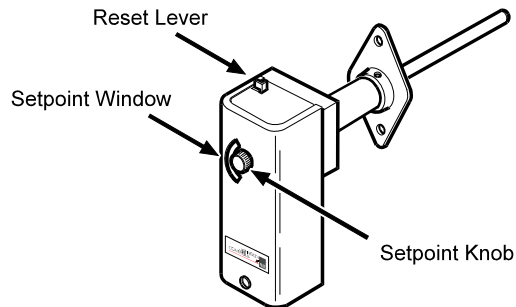

Figure 7: Models A25AN and A25CN

Models A25AP and A25CP

Setpoint Adjustment: Loosen the cover screw (Figure 8) and remove the cover. Adjust the setpoint by rotating the adjusting screw. When adjusted, re-install the cover. Tighten cover screw.

Test Procedure:

To test (trip) the A25: Raise the temperature at the sensor above the setpoint or lower the setpoint below the ambient temperature. The control should lockout (trip).

To reset after test: Lower the temperature at the sensor to 20F° (11C°) below the setpoint or raise the setpoint to 20F° (11C°) above the ambient temperature. Press the reset lever. The A25 should reset (closing the circuit).

Reset Procedure: Verify that the temperature has dropped 20F° (11C°) below setpoint. Press the reset lever to reset the A25 (closing the circuit).

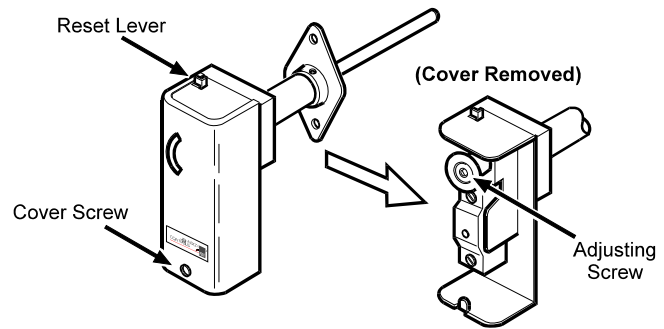

Figure 8: Models A25AP and A25CP

Dimensions

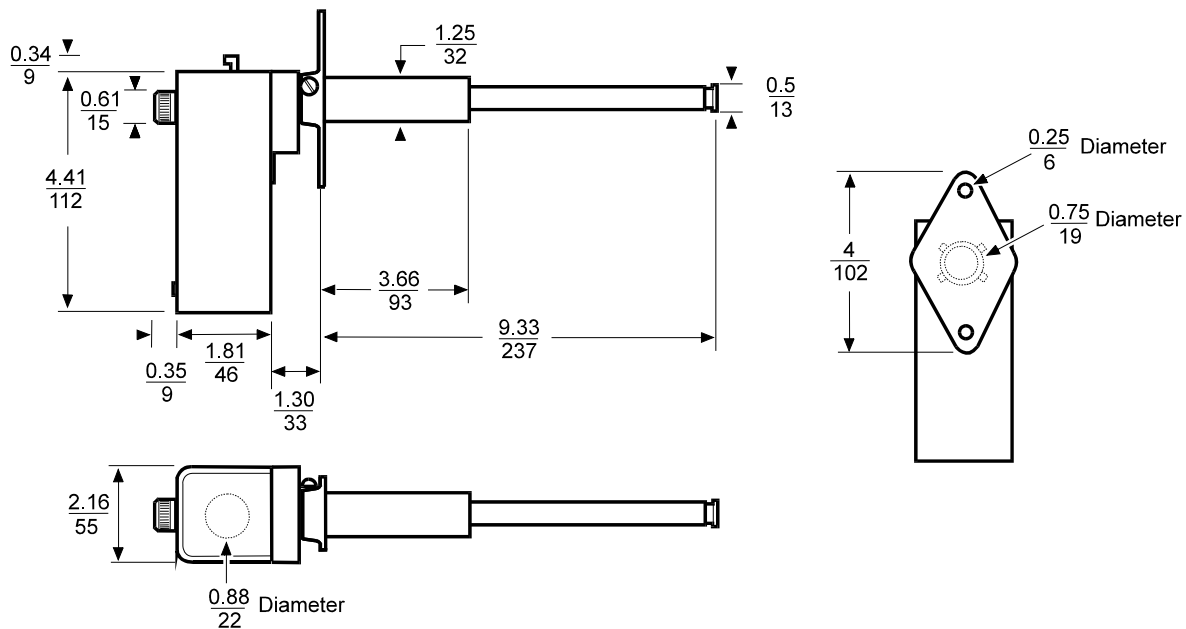

Figure 9: A25 Dimensions, in./mm

Repairs and Replacement

Do not make field repairs. For a replacement control, contact your nearest Johnson Controls representative.

Table 1: Ordering Information

Item	Product Code Number	Product Description
A25 Series Warm Air Control with Manual Reset	A25AN-1	SPST, opens on temperature rise, setpoint knob adjustment.
	A25AP-1	SPST, opens on temperature rise, concealed screwdriver adjustment, Factory Mutual approved.
	A25CN-1	SPDT, setpoint knob adjustment.
	A25CP-1	SPDT, concealed screwdriver adjustment, Factory Mutual approved.

Troubleshooting

Table 2: Troubleshooting Chart

Symptom	Problem	Solution
The A25 is not sensing properly.	The sensing element may not be extended into the airstream or the sensing element is contacting an object inside of the duct (or plenum).	Insert the sensing element as far as possible into the airstream without allowing it to contact any object inside the duct (or plenum).
The system does not operate.	Incorrect switch connections or improper wiring. Damaged sensor. The A25 is tripped.	Ensure that the wiring connections follow the wiring diagrams in the <i>Wiring</i> section. Check connections. Replace the A25. Reset the A25.
A25 does not lockout upon a temperature rise beyond the setpoint.	The A25 is defective.	Replace the A25.
The A25 does not sense the correct air temperature.	The A25 is defective.	Replace the A25.
A25 will not reset.	The temperature in the duct (or plenum) is not 20F° (11C°) below the setpoint.	Check system for overheating or fire.

Notes

Specifications

Product	A25AN-1	SPST, opens on temperature rise, setpoint knob adjustment.			
	A25AP-1	SPST, opens on temperature rise, concealed screwdriver adjustment, Factory Mutual approved.			
	A25CN-1	SPDT, setpoint knob adjustment.			
	A25CP-1	SPDT, concealed screwdriver adjustment, Factory Mutual approved.			
Range	25 to 215°F (-4 to 102°C)				
Electrical Ratings	Volts, AC	120 VAC	208 VAC	240 VAC	277 VAC
	Motor FLA*	16	9.2	8	-
	Motor LRA*	96	55.2	48	-
	Noninductive A	16	16	16	16
Pilot Duty: 125 VA at 24/600 VAC					
Ambient Temperature (Maximum)	Case	104°F (40°C)			
	Element	300°F (149°C)			
Conduit Opening	7/8 in. (22 mm) diameter hole for 1/2 in. conduit				
Switch	Snap-acting contacts in dust protected enclosure				
Cover Finish	Gray baked enamel				
High Limit Dial Stop	125°F				
Material	Case	0.063 in. (1.6 mm) galvanized steel			
	Cover	0.025 in. (0.64 mm) cold rolled steel			
Mounting	Flange for flat surface				
Reset	Positive, trip-free reset mechanism (manual reset 2 operation). Control can be reset when the temperature drops 20F° (11C°) below the dial setting.				
Sensing Element	Bi-metal rod and tube construction				
Shipping Weight	Individual pack	1.8 lb. (0.8 kg)			
	Overpack of 12 units	23 lb. (10.4 kg)			
Wiring Connections	Screw-type terminals				
Agency Listing	UL Recognized: File MP640, Guide MBPR CSA Certified: File LR948, Class 4813 02 Factory Mutual Approved (Models A25AP and A25CP only): Class 3545				

* FLA = Full Load Amps; LRA = Locked Rotor Amps. Values are equivalent to a 1 HP motor rating in accordance with UL353.

The performance specifications are nominal and conform to acceptable industry standards. For application at conditions beyond these specifications, consult the local Johnson Controls office. Johnson Controls, Inc. shall not be liable for damages resulting from misapplication or misuse of its products.

European Single Point of Contact:

JOHNSON CONTROLS
WESTENDHOF 3
45143 ESSEN
GERMANY

NA/SA Single Point of Contact:

JOHNSON CONTROLS
507 E MICHIGAN ST
MILWAUKEE WI 53202
USA

APAC Single Point of Contact:

JOHNSON CONTROLS
C/O CONTROLS PRODUCT MANAGEMENT
NO. 22 BLOCK D NEW DISTRICT
WUXI JIANGSU PROVINCE 214142
CHINA



Controls Group
507 E. Michigan Street
P.O. Box 423
Milwaukee, WI 53201

Printed in U.S.A

DUCT AND IMMERSION BUILDING AUTOMATION TEMPERATURE SENSORS

Available up to 18" Probe Length, Thermistor or RTD Outputs

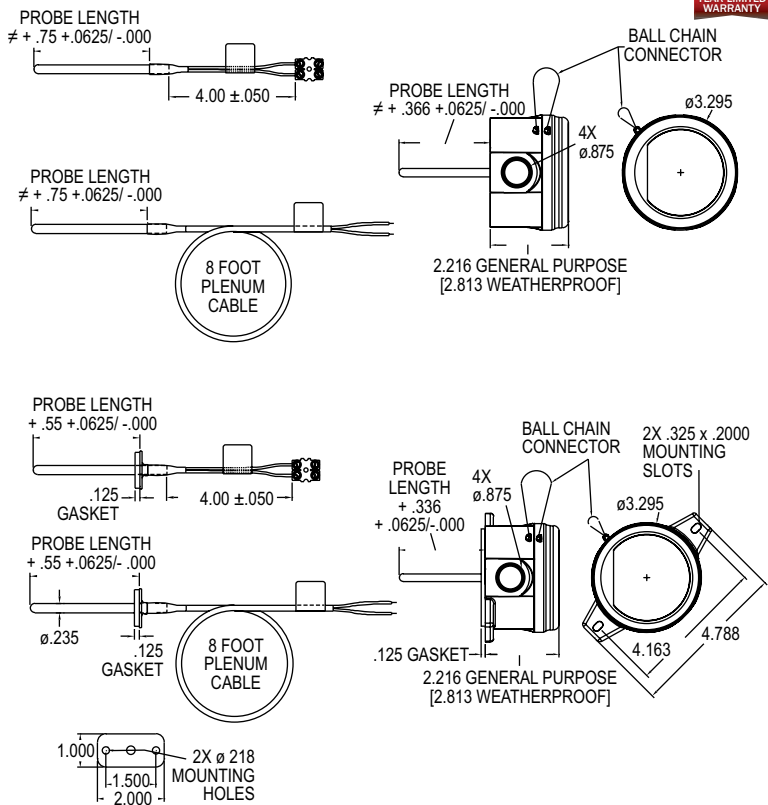

The **Series TE Duct and Immersion Building Automation Temperature Sensors** can be used to monitor air or water temperature throughout a building management system or an air handler unit. Duct or immersion options available with or without an enclosure.

BENEFITS/FEATURES

- Easy to mount external tab housing and flange options for duct applications
- 1/4 turn housing cover with chain to prevent dropping
- Multiple conduit knockouts for easy installation positioning
- 8' plenum rated cable option
- Terminal connector eliminates need for wire nuts

APPLICATIONS

- Building automation
- VAV temperature sensing
- Chiller or boiler loops
- AHU monitoring

SPECIFICATIONS

Accuracy: Thermistor temperature sensor: $\pm 0.22^{\circ}\text{C}$ @ 25°C ($\pm 0.4^{\circ}\text{F}$ @ 77°F); RTD temperature sensor: DIN class A: $\pm 0.15^{\circ}\text{C}$ @ 0°C ($\pm 0.28^{\circ}\text{F}$ @ 32°F).

Temperature Limits: Operating: -40 to 302°F (-40 to 150°C).

Sensor Curves: See page reference 1 below.

Cable Rating: Plenum option includes UL listed plenum cable.

Housing Material: Meets UL, 94 V-0 polycarbonate plastic.

Housing Rating: NEMA 4X (IP66) (DFW, IBW only).

Weight: 5.3 oz (150.3 g).

Compliance: Meets the technical requirements of EU Directive 2011/65/EU (RoHS II).

MODEL CHART								
Example	TE	-DFN	-A	04	4	8	-00	TE-DFN-A0448-00
Series	TE							Temperature sensor
Mounting Configuration		DFN DFG DFW IBN IBG IBW						Duct mount probe only Duct mount probe in general purpose housing Duct mount probe in NEMA 4X housing Immersion probe only Immersion probe in general purpose housing Immersion probe in NEMA 4X housing
Sensor Type			A B C D E F Q					10k Ω type III thermistor 10k Ω type II thermistor 3k Ω thermistor Pt100 Ω RTD Pt1000 Ω RTD 20k Ω thermistor 10k Ω type III with 11k Ω shunt
Probe Length				25 04 06 08 12 18				2.5" 4" 6" 8" 12" 18" (DFN/DFG only)
Probe Diameter					4			1/4" double encapsulated
Termination						3 4 7 8		4" leads with spade connectors 4" leads 8' plenum rated cable with spade connectors 8' plenum rated cable
Fittings							00 12 14	None (probe only) 1/2" NPT compression fitting 1/4" NPT compression fitting

1 Resistance vs. Temperature Table: See page 137 (Series TE-OND/RND/OSA)

WALL MOUNT HUMIDITY/TEMPERATURE/DEW POINT TRANSMITTERS

Optional LCD Display

CALIBRATION SERVICES AVAILABLE



European style



North American style

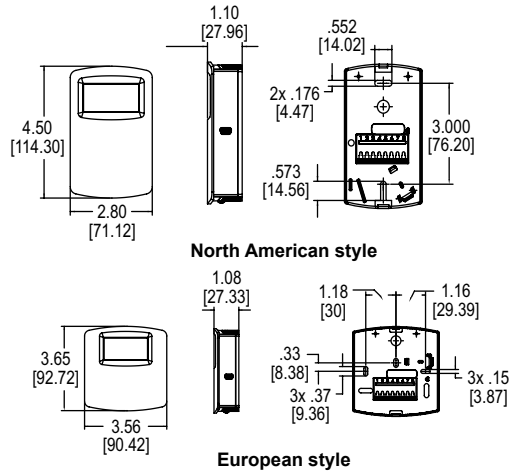

The Series RHP-E/N Wall Mount Humidity/Temperature/Dew Point Transmitters are the most versatile room transmitter on the market. The stylish housing is well vented to provide air flow across the sensor to improve measurement accuracy. The humidity and the dew point are measured using a capacitive polymer sensor. The humidity and dew point can have either a current or voltage output, while the optional temperature output can be a current, voltage, RTD or thermistor. For models with current or voltage for the temperature output, the temperature range is field selectable.

BENEFITS/FEATURES

- Reduced installation cost with combined humidity/dew point and temperature sensing
- Wide application environments from a large selection of temperature sensors and 2% and 3% accuracies
- Reduced inventory with field selectable output

APPLICATIONS

- Air economizers
- Room comfort monitoring
- Greenhouse monitoring

SPECIFICATIONS

Relative Humidity Range: 0 to 100% RH.
Temperature Range: -40 to 140°F (-40 to 60°C) for thermistor and RTD sensors. -20 to 140°F (-28.9 to 60°C) for solid state band gap temperature sensors.
Dew Point Temperature Range: -20 to 140°F (-28.9 to 60°C); 0 to 100°F (-17.8 to 37.8°C); 40 to 90°F (4.4 to 32.3°C); -4 to 140°F (-20 to 60°C) field-selectable ranges.
Accuracy: RH: Model RHP-2XXX ±2% 10 to 90% RH @ 25°C; Model RHP-3XXX ±3% 20 to 80% RH @ 25°C; Model RHP-5XXX ±5% 20 to 80% RH @ 25°C; Thermistor temperature sensor: ±0.36°F @ 77°F (±0.2°C @ 25°C); RTD temperature sensor: DIN Class B; ±0.54°F @ 32°F (±0.3°C @ 0°C); Solid state band gap temperature sensor: ±0.9°F @ 77°F (±0.5°C @ 25°C).
Hysteresis: ±0.8%.
Repeatability: ±0.1% typical.
Temperature Limits: Operating: -40 to 140°F (-40 to 60°C); Storage: -40 to 176°F (-40 to 80°C).
Compensated Temperature Range: -4 to 140°F (-20 to 60°C).
Power Requirements: 4-20 mA loop powered outputs: 10-35 VDC; 0-5/10V outputs: 15-35 VDC or 15-29 VAC.
Output Signals: 4-20 mA loop powered outputs: 4-20 mA, 2 channels for humidity/solid state temperature sensor models (loop powered on RH). Switch selectable RH/dew point. Switch selectable normal or reverse output; 0-5/10V outputs: 5 mA max., 2 channels for humidity/solid state temperature sensor models. Switch selectable 0-10 V/2-10 V or 0-5 V/1-5 V output. Switch selectable RH/dew point. Switch selectable normal or reverse output.
Solid State Band Gap Temperature Sensor Output Ranges: Switch selectable, -20 to 140°F (-28.9 to 60°C); 0 to 100°F (-17.8 to 37.8°C); 40 to 90°F (4.4 to 32.3°C); -4 to 140°F (-20 to 60°C).
Response Time: 8 s.
Electrical Connections: Screw terminal block.
Drift: <0.25% RH/year.
RH Sensor: Capacitance polymer.
Enclosure Material: Polycarbonate.
Enclosure Rating: IP20.
Display: Optional LCD; Switch selectable %RH or dew point, °F/°C.
Display Resolution: RH: 1%; Temperature: 0.1°F (0.1°C); Dew point: 1°F (1°C).
Weight: 4.4 oz (125 g).
Compliance: CE.

MODEL CHART						
Example	RHP	-3	N	A	-LCD	RHP-3N4A-LCD
Series	RHP					Humidity/temperature dew point transmitter
Accuracy		2 3 5				2% accuracy 3% accuracy 5% accuracy
Housing			E N			European style wall mount North American style wall mount
Humidity/Dew Point Output				4		4-20 mA/0-5 VDC/0-10 VDC
Temperature Output				0 4 A B C D E F		None 4-20 mA/0-5 VDC/0-10 VDC 10K Ω @ 25°C thermistor type III 10K Ω @ 25°C thermistor type II 3K Ω @ 25°C thermistor 100 Ω RTD DIN 385 1K Ω RTD DIN 385 20K Ω @ 25°C thermistor
Options					LCD NIST	LCD display NIST traceable calibration certificate

ACCESSORIES

Model	Description
A-449	Remote LCD display allows remote indication of select Dwyer wall mount transmitters for validation or certification purposes
SCD-PS	100-240 VAC/VDC to 24 VDC power supply



A-449

Humidity/Temperature Transmitters

Specifications for the Wet Switch® Flood Detector



Relay:

- Isolated Contacts
- 2 Amps: NC Contact
- 2 Amps: NO Contact

Indicators:

- Red LED : Moisture Detected
- Green LED: Power

Power Requirements:

- 18-30 VAC, 60 Hz
- 20-30 VAC, 50 Hz
- 1.5 Watts Max (wet), <0.5 Watts (dry)

Typical Connection

Cooling System Transformer

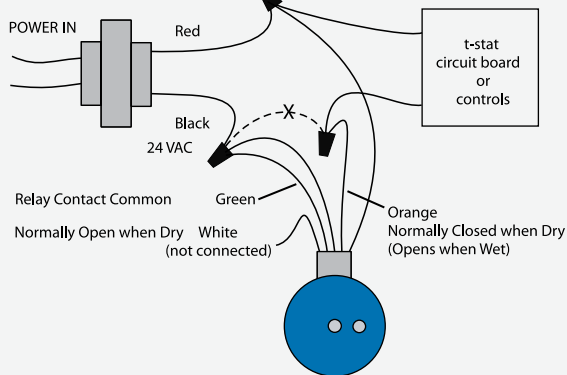

Connection showing two or more Wet Switches in series

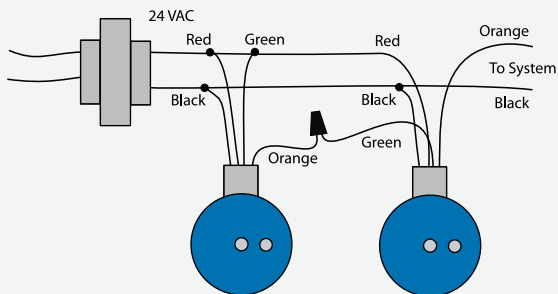

The contacts of the Wet Switch's relay may be wired to use multiple Wet Switches. The drawing above shows the contacts interrupting the 24 VAC signal when either Wet Switch® gets wet.

About DiversiTech

DiversiTech Corporation is North America's largest manufacturer of equipment pads and a leading manufacturer and supplier of components and related products for the heating, ventilating, air conditioning, and refrigeration (HVACR) industry.

Headquartered in the Atlanta, GA metropolitan area, DiversiTech manufactures a suite of products which includes a wide range of mechanical, electrical, chemical, and structural parts for HVACR and electrical systems, and swimming pool installations. The company maintains manufacturing and distribution facilities in key U.S. locations, Europe, and in the Far East. DiversiTech has enjoyed a continued history of successful growth and has acquired industry-recognized names including Devco® Enterprises, Wagner® Manufacturing, The Black Pad®, Hef-T-Pad™ and Specialty Chemical.

WET SWITCH® FLOOD DETECTOR



Download an electronic version of this brochure at:
<http://media.diversitech.com/doc/DOC00015.pdf>

DiversiTech Corporation
 6650 Sugarloaf Parkway
 Duluth, GA 30097
800.995.2222
678.542.3700 FAX
www.diversitech.com

U.S. Patent No. 4,787,212
 ©2013 DiversiTech Corporation
 LIT-FLY-WS, 6/13



What is the Wet Switch® Flood Detector?

The Wet Switch® Flood Detector is a solid state device designed to detect the presence of condensate water overflow.

Simply place the Wet Switch® Flood Detector into the secondary drain pan — a normally dry pan. If the primary drain pan fails, condensate water will overflow into the secondary drain pan. Upon sensing moisture, the Wet Switch® Flood Detector will turn the system off (typically the cause of the condensing water) to help prevent damage to carpets, walls, woodwork, ceilings, and other property.

- Hydrophilic Pad
- Integral Feet
- Solid State Electronics
- Double Throw Relay
- Standard 24VAC control
- Multiple Unit Connectivity
- Stainless Steel Sensor Array
- Epoxy Encapsulated Electronics

The Wet Switch® Flood Detector is designed to interrupt the operation of cooling systems. However, it is a water activated switch and can be used in a variety of other applications.

Features and Benefits of the Wet Switch® Flood Detector

Hydrophilic Pad

A high tech polymeric fiber quickly draws water into the sensor array using proven capillary technology.

Integral Feet

Integral feet raise the hydrophilic pad and sensor array off the drain pan slightly to prevent nuisance tripping, and pan corrosion (metal pans only) from interfering with the sensor array.

Stainless Steel Sensor Array

A high tech array of multiple stainless steel sensors detects even a minimal amount of water drawn into the hydrophilic pad.

Compact Package

The technology is packed into a 3-5/8" diameter by 1-1/4" high cylinder, furnished complete with 5-conductor 22AWG stranded cable, 6' long.

Solid State Electronics

Proven electronics prevent mechanical failure in an aggressive operating environment.

Double Throw Relay

Allows for the wiring to interrupt the system and sound an alarm (by others) when moisture is detected.

Multiple Unit Connectivity

Multiple unit connectivity allows for multiple Wet Switch® Flood Detectors to be connected in series to adequately cover large drain pan areas.

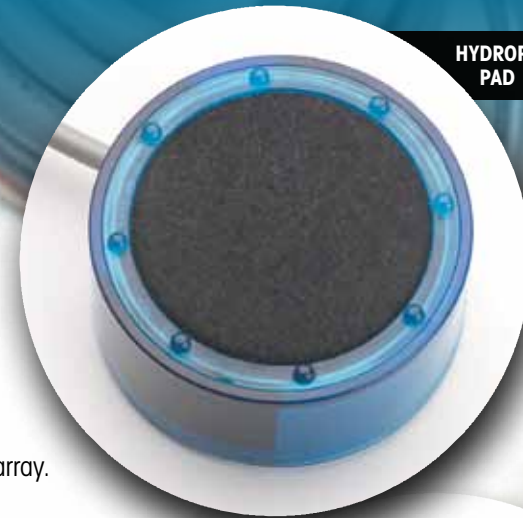
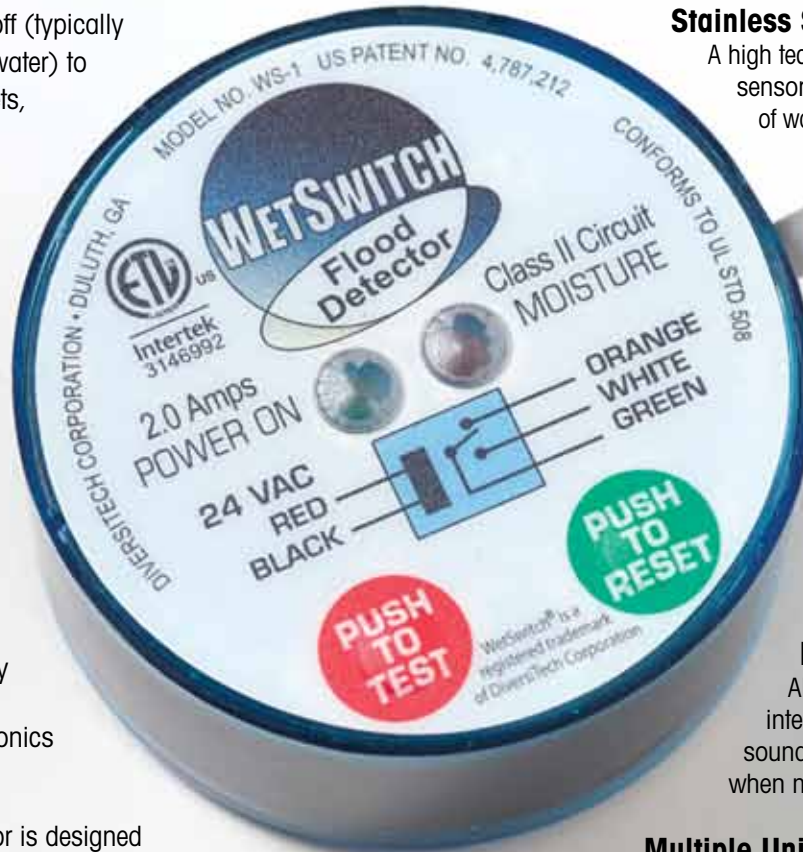

HYDROPHILIC PAD



INTEGRAL FEET



STAINLESS STEEL SENSORS

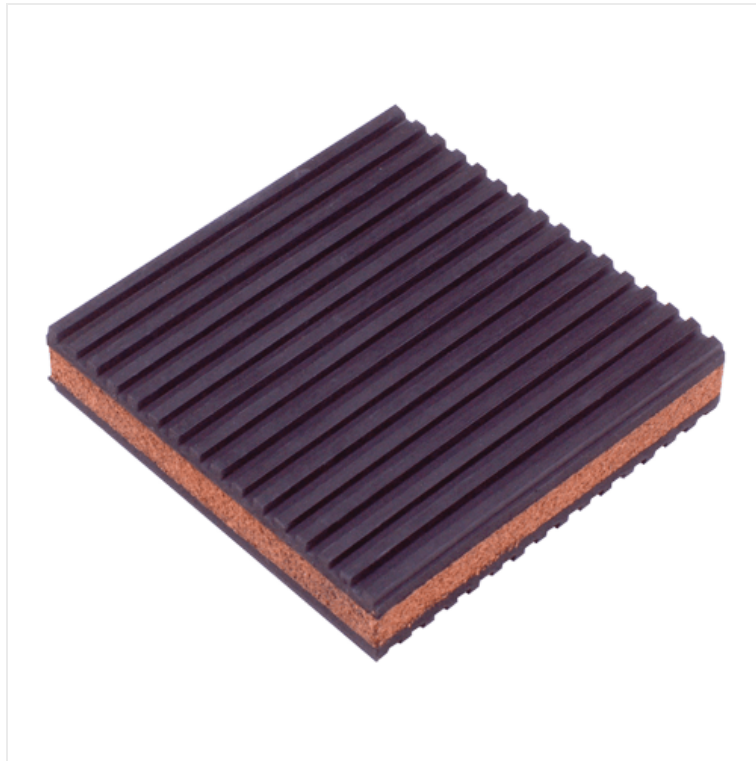

RUBBER/CORK ANTI-VIBRATION PAD, 4IN. X 4IN. X 7/8IN.

Item#: **MP-4C**

The DiversiTech® MP-4C is a 4 in. x 4 in. x 7/8 in. rubber/cork anti-vibration pad designed to reduce vibration and noise emanating from refrigeration and air conditioning equipment. Rubber pads laminate to the cork center providing excellent vibration and noise reduction. Corrugated ribs on top and bottom reduce "walking" or "creep" associated with vibration. These pads are designed to withstand 50 psi.

Product Features & Benefits ▲

- The top and bottom ribs are 90 degrees opposed to one another providing a natural resistance to "creep" or "walking" associated with vibrations
- Ideal for air conditioners, refrigeration equipment, compressors, cooling towers, presses, machines or anywhere vibration control is needed.

- Designed to withstand loads of 50 psi
- Pads can be stacked using interlocking ribs if additional vibration absorption or height is desired
- Other size options available from 2 in. x 2 in. to 18 in. x 18 in.

Specifications ▲

Color	Black Brown
Application	Compressor Condensers Cooling Tower Generator Motor Other Press Pumps
Texture	Corregated Ribbed
Size	4x4x7/8 in.
Indoor / Outdoor Use	Indoor
Durometer	50
PSI Rating	50
Ducted or Ductless	Both Ducted and Ductless

Order Info ▲

UPC	0686109670056
Primary UoM	Each
Primary Depth (inches)	4
Primary Width (inches)	4
Primary Height (inches)	0.94
Primary Weight (lbs)	0.37
Quick Ship Flag	Yes
Order Multiple	24

Analog Points				
Point	Description	High Limit	Low Limit	R/W
AV0_TempSetPt	Temp set pt	95.0	40.0	Writable
AV1_TempDeadbnd	Zone Deadband	20.0	0.0	Writable
AV2_ZoneTempHiAlrm	Zone temp high alarm set pt	150.0	0.0	Writable
AV3_ZoneTempLowAlrm	Zone temp alarm low set pt	120.0	0.0	Writable
AV4_ZoneRhSetPt	Zone RH set pt	90.0	10.0	Writable
AV5_ZoneRhDeadbnd	Zone RH deadband	20.0	0.0	Writable
AV6_ZoneRhHiAlrm	Zone RH high alarm	100.0	0.0	Writable
AV7_ZoneRhLowAlrm	Zone RH low alarm set pt	100.0	0.0	Writable
AV8_WaterTempSetPt	Freecool or dual cool set point	80.0	0.0	Writable
AV9_CO2SetPt	CO2 set point	2000.0	500.0	Writable
AV10_SplyTempHiAlrm	Supply temp high alarm set pt	150.0	0.0	Writable
AV11_SplyTempLowAlrm	Supply temp low alarm set pt	150.0	0.0	Writable
AV12_StaticPSetPt	Duct static pressure set pt	20.0	0.0	Writable
AV13_SplyFanMin	Supply fan minimum set pt	100.0	30.0	Writable
AV14_SplyFanDesign	Supply fan design set point	100.0	30.0	Writable
AV15_SplyFanDehum	Supply fan dehum set back	100.0	30.0	Writable
AV16_DamperMin	Damper minimum position	100.0	0.0	Writable
AV17_DamperMax	Damper max position for CO2	100.0	0.0	Writable
AV18_AseDbSetPt	ASE dry bulb set pt	80.0	0.0	Writable
AV19_AseMixSetPt	ASE mixed air set point	80.0	0.0	Writable
AI0_StaticPress	Duct static pressure	20.0	0.0	Read Only
AI1_RetTemp	Return air temp	150.0	-50.0	Read Only
AI2_OutdoorRh	Outdoor air rh	100.0	0.0	Read Only
AI3_OutdoorTemp	Outdoor air temp	150.0	-50.0	Read Only
AI4_SplyTemp	Supply air temp	150.0	-50.0	Read Only
AI5_ZoneCO2	Zone CO2	3000.0	0.0	Read Only
AI6_ZoneRh	Zone relative hum	100.0	0.0	Read Only
AI7_ZoneTemp	Zone temp	150.0	-50.0	Read Only
AI8_WaterTemp	Free or dual cool water temp	150.0	-50.0	Read Only
AI9_Condenser	Condenser analog out	100.0	0.0	Read Only
AI10_ClgVlv	Cooling valve analog out	100.0	0.0	Read Only
AI11_Compressor	Compressor analog out	100.0	0.0	Read Only
AI12_Damper	Damper analog out	100.0	0.0	Read Only
AI13_Heater	Heater analog out	100.0	0.0	Read Only
AI14_HotGasReheat	Hot gas reheat analog out	100.0	0.0	Read Only
AI15_SplyFan	Supply fan analog out	100.0	0.0	Read Only

Binary Points				
Point	Description	-	-	R/W
BV0_AhuEn	Unit HMI enable	-	-	Writable
BV1_EnCooling	Allow cooling operation	-	-	Writable
BV2_EnDehum	Allow dehumidification operation	-	-	Writable
BV3_EnHeating	Allow heating operation	-	-	Writable
BV4_EnHum	Allow humidification operation	-	-	Writable
BV6_BMSOff	BMS point to enable/disable unit operation	-	-	Writable
BV8_AlarmReset	Reset all active alarms	-	-	Writable
BI0_AirProving	Air proving alarm	-	-	Read Only
BI1_DirtyFilter	Dirty filter alarm	-	-	Read Only
BI2_LifeSafety	Life safety alarm	-	-	Read Only
BI3_Condensate	Condensate overflow alarm	-	-	Read Only
BI4_FreezeStat	Freezestat alarm	-	-	Read Only
BI5_WaterProving	Water proving alarm	-	-	Read Only
BI6_GlobalAlarm	Global alarm status	-	-	Read Only
BI7_Ckt1LowPress	Circuit 1 low refrigerant pressure alarm	-	-	Read Only
BI8_Ckt1HiPress	Circuit 1 high refrigerant pressure alarm	-	-	Read Only
BI9_Ckt2LowPress	Circuit 2 low refrigerant pressure alarm	-	-	Read Only
BI10_Ckt2HiPress	Circuit 2 high refrigerant pressure alarm	-	-	Read Only
BI11_HiZoneTemp	High zone temp alarm	-	-	Read Only
BI12_LowZoneTemp	Low zone temp alarm	-	-	Read Only
BI13_HiZoneRh	High zone RH alarm	-	-	Read Only
BI14_LowZoneRh	Low zone RH alarm	-	-	Read Only
BI15_HiSplyTemp	High supply temp alarm	-	-	Read Only
BI16_LowSplyTemp	Low supply temp alarm	-	-	Read Only
BI17_HiZoneCo2	High zone CO2	-	-	Read Only
BI18_Ckt1Comp1	Circuit 1 compressor 1 output	-	-	Read Only
BI19_Ckt1Comp2	Circuit 1 compressor 2 output	-	-	Read Only
BI20_Ckt2Comp1	Circuit 2 compressor 1	-	-	Read Only
BI21_Ckt2Comp2	Circuit 2 compressor 2 output	-	-	Read Only
BI22_ClgVlv	Cooling Valve output	-	-	Read Only
BI23_Condenser	Condenser output	-	-	Read Only
BI24_Heater1	Heater 1 output	-	-	Read Only
BI25_Heater2	Heater 2 output	-	-	Read Only
BI26_HotGasReheat	Hot gas reheat output	-	-	Read Only
BI27_Humidifier	Humidifier output	-	-	Read Only
BI28_PumpEnable	Pump enable output	-	-	Read Only
BI29_SplyFan	Supply fan output	-	-	Read Only
BI30_Damper	Damper output	-	-	Read Only
BI31_AhuOn	Current unit status	-	-	Read Only
BI32_NetOff	Unit disabled by multi-unit sequencing	-	-	Read Only
BI33_AlarmShutdown	Unit disabled by active alarms	-	-	Read Only



COOK



MARK: DH RELIEF
PROJECT: DC 10MW
DATE: 09/27/2024

LXUL

**Low Silhouette
Upblast Exhaust Ventilator
Low Pressure X-Stream Propeller
Roof Mounted/Belt Drive**

STANDARD CONSTRUCTION FEATURES:

X-Stream steel propeller - All non-galvanized steel components finished with Lorenized baked powder coat - 14 gauge spun steel Venturi/curb cap - 14 gauge steel lower drum - Minimum 18 gauge steel windband - Welded tubular steel power assembly - 2 point lifting lugs - Aluminum butterfly damper doors (20-36) - Galvanized steel butterfly dampers (42-60) - Welded curb cap corners - Adjustable pitch drives through 5 hp - Regreasable bearings in cast housing, rated at 200,000 hours average life - Propellers are statically and dynamically balanced - Corrosion resistant fasteners - Oil and heat resistant, static conducting belts - All fans factory adjusted to specified RPM

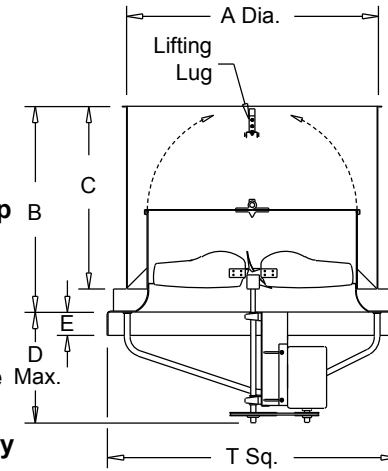

Performance (*Bhp includes 6% drive loss)

Qty	Catalog Number	Flow (CFM)	SP (in.)	Fan RPM	Power* (HP)	FEG	FEI
10	60 LXUL	44700	.250	436	6.18	67	1.14

Altitude (ft): 5312 Temperature (F): 95

Motor Information

HP	RPM	Volts/Ph/Hz	Enclosure	FLA	Mounted	VFD Rated
10	1725	460/3/60	ODP -PE	14	No	Yes

NEMA Premium® efficiency motor per MG-1 (2014) Table 12-12
FLA based on NEC (2017) Table 430.250

Sound Data Inlet Sound Power by Octave Band

1	2	3	4	5	6	7	8	LwA	dBA	Sones
93	97	95	85	82	77	74	67	90	79	33

- Distance from Sound source 5 ft

Accessories:

- Premium Efficiency Motor (Min. 91.7%)
- DRIVES (1.5 SF) @ 436 RPM
- ROOF CURB RCG 70 24H -C-T-N SL-1:12
- DRIP PAN
- MAGNETIC LATCHES
- ANTICONDENSATE COAT
- BELT TENSIONR-ROTARY

Dimensions (inches)

A Dia.	67-1/4
B	51
C	49
D Max.	28
E	3
T Sq.	72
Roof Open.	67-1/2

NOTE: Accessories may affect dimensions shown.

Weight(lb)***	Shipping	1781	Unit	1033
---------------	----------	------	------	------

***Includes fan, motor & accessories.

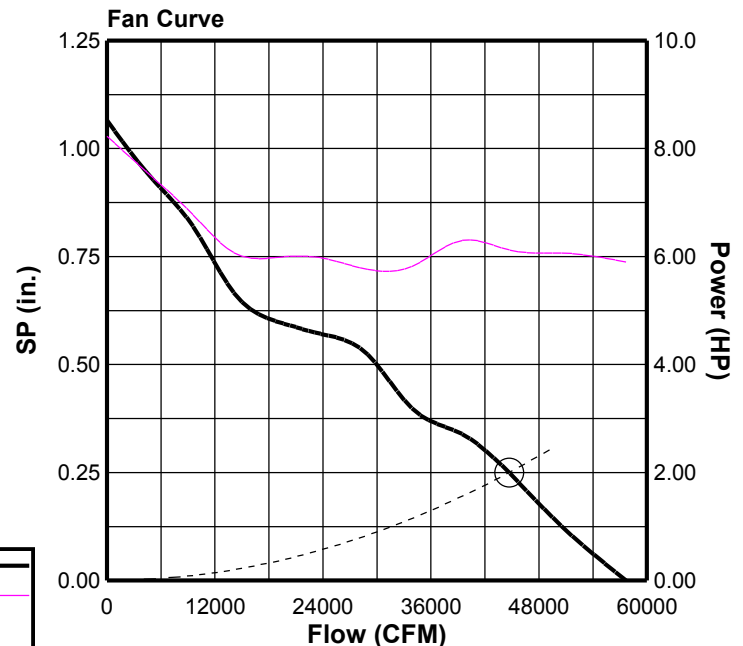



COOK



MARK: ELEC RELIEF OPTION
PROJECT: DC 10MW
DATE: 09/27/2024

HXEL

Hooded Exhaust Ventilator Low-Pressure Steel Propeller Roof Mounted/Belt Drive

STANDARD CONSTRUCTION FEATURES:

X-stream steel propeller - Spun steel Venturi/curb cap - Lorenized steel lower housing - Galvanized steel hood - Birdscreen - Heavy duty steel power assembly - Welded curb cap corners - Adjustable pitch drives through 5 hp motor - Regreasable bearings in cast housing rated at 200,000 hours average life - Propellers are statically and dynamically balanced - Corrosion resistant fasteners - Oil and heat resistant, static conducting belts - All fans factory adjusted to specified RPM.

NOTE: Sizes 42-60 require field assembly of hood.

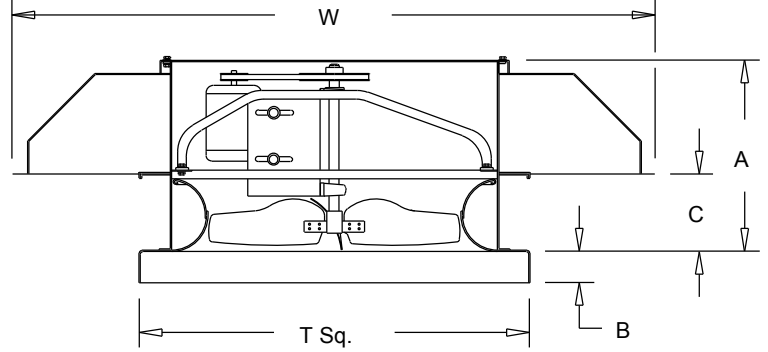

Performance (*Bhp includes 5% drive loss)

Qty	Catalog Number	Flow (CFM)	SP (in.)	Fan RPM	Power* (HP)	FEG	FEI
1	60HXEL13B	45000	.250	474	9.07	<50	0.81

Altitude (ft): 5312 Temperature (F): 70

Motor Information

HP	RPM	Volts/Ph/Hz	Enclosure	FLA	Mounted	VFD Rated
10	1725	460/3/60	ODP -PE	14	No	Yes

NEMA Premium® efficiency motor per MG-1 (2014) Table 12-12
FLA based on NEC (2017) Table 430.250

Sound Data Inlet Sound Power by Octave Band

1	2	3	4	5	6	7	8	LwA	dBA	Sones
90	92	89	86	83	81	79	73	89	77	30

- Distance from Sound source 5 ft

Accessories:

- Premium Efficiency Motor (Min. 91.7%)
- DRIVES (1.5 SF) @ 474 RPM
- BD MOTORIZED INTAKE CTR PIVOT LA-66-24V
- ROOF CURB RCG 70 24H -C-T+N SL-1:12
- ENAMEL-CURB
- GASKET W/NAILER-CURB
- ANTICONDENSATE COAT
- LIFTING LUGS - SHIPPED LOOSE
- ALUMINUM HOOD
- EXTENDED BASE HXB-70
- BELT TENSIONR-ROTARY

Dimensions (inches)

A	44-1/2
B	3
C	14-3/4
L x W	121 x 119
T Sq.	72
Base Ga.	14
Hood Ga.	18
Roof Open.Sq.*	67-1/2

NOTE: Accessories may affect dimensions shown.

Weight(lb)***	Shipping	2078	Unit	1657
---------------	----------	------	------	------

*ROOF OPENING SIZE FOR CURBS SUPPLIED BY COOK ONLY.
***Includes fan, motor & accessories.

Fan Curve

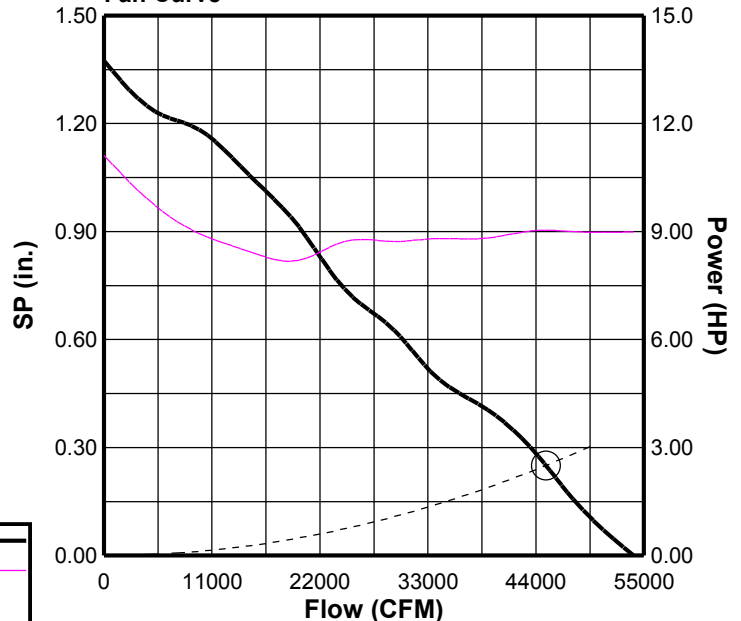

Fan Curve Legend

CFM vs SP	—
CFM vs HP	—
Point of Operation	○
System Curve	- - -



RCG SLOPED

Galvanized Steel Roof Curb

STANDARD CONSTRUCTION FEATURES:

18 gauge galvanized steel - 1-1/2", 3 lbs.
density thermal and acoustical insulation -
Continuously welded corners - Wood nailer.

Options:(As noted below*)

- 1) No wood nailer (deduct 1-1/2" for actual height)
- 2) Drop-in damper tray.
- 3) Liner.
- 4) Gasket on wood nailer.
- 5) Lorenized coating.
- 6) Enamel coating.
- 7) Burglar bars.

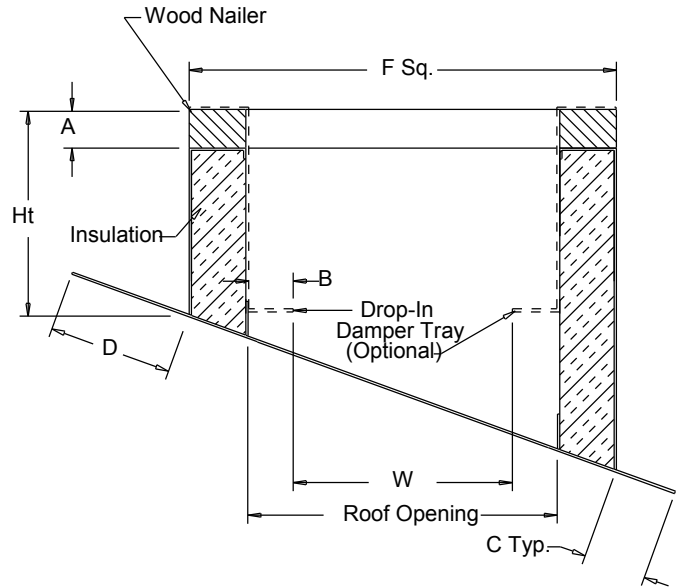

Dimensions (inches)

Mark	Qty	Description	Ht	Options* Rise/Run	A	B	C	D	F Sq.	W Sq.	Roof Opening
DH RELIEF	10	RCG 70	24	4; 1:12	1.5	1.875	2	6	70.5	63.75	67.5 X 67.5
ELEC RELIEF	1	RCG 70	24	4; 6; 1:12	1.5	1.875	2	6	70.5	63.75	67.5 X 67.5
ELEC RELIEF OPTION	1	RCG 70	24	4; 6; 1:12	1.5	1.875	2	6	70.5	63.75	67.5 X 67.5



COOK

PROJECT: DC 10MW

DATE: 09/27/2024

Motorized Damper

Low Leakage Class 1A Rated Aluminum

STANDARD CONSTRUCTION FEATURES:

- Frame: 5" x 1" x 6063T5 extruded hat channel with .125" minimum wall thickness.
- Blades: 6" wide, 6063T5 heavy gauge extruded aluminum, airfoil shape. Opposed blade standard.
- Seals: Synthetic polymer blade edge seals and flexible metal compressible jamb seals.
- Bearings: Molded synthetic.
- Linkage: Concealed in frame.
- Axles: 1/2" plated steel hex.
- Temperature Limits: -72 to +275 deg. Fahrenheit.
- Actuator in Airstream available in 24v, 115v, (230v and 460v with transformer). Power Open/spring Close
- MIN 13-1/2" CURB HT REQUIRED IF CURB MOUNTED.

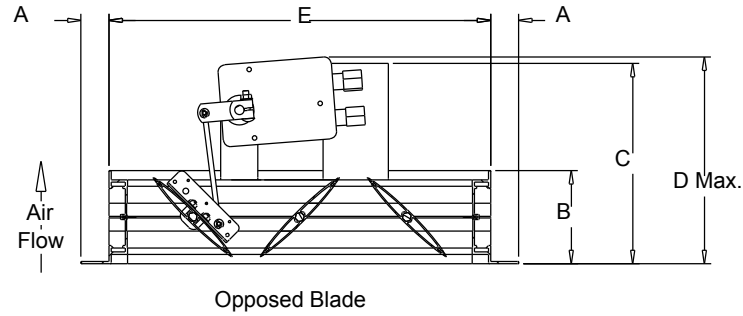
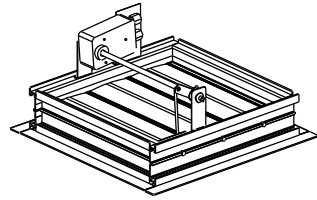

Dimensions (inches)

Mark	Qty	Description	A	B	C	D Max	E	Num. Actuators
ELEC RELIEF OPTION	1	BDMICLA-66-24V	1-1/2	5	10-3/4	11-1/2	62-3/4	1



HXB

Heavy Duty Extended Base With Damper Access Door

STANDARD CONSTRUCTION FEATURES:

- 18 gauge galvanized steel construction -
- One removable side panel.

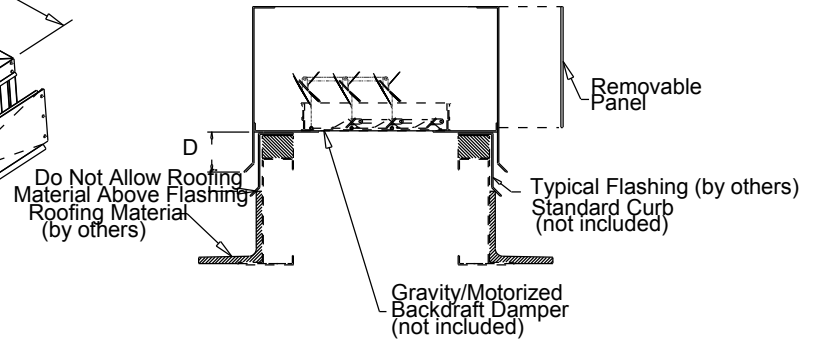
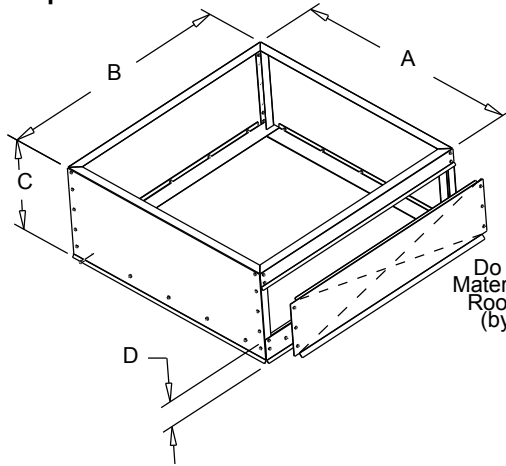

Dimensions (inches)

Mark	Qty	Description	A	B	C	D
ELEC RELIEF OPTION	1	EXTENDED BASE HXB-70	71-9/16	71-5/8	21-19/32	2-7/16



Unit Rating

2425 South Yukon Ave • Tulsa, OK 74107 • Ph: (918) 583-2266
Ecat Version: 345.0

1A 1B 1C 1D 2 3 4 5A 5B 5C 6A 6B 6C 7 8 9 10 11 12 13 14A 14B 15 16 17 18 19 20 21 22 23

RN-006-3-0-G60C-12A:A000-CLB-DBD-AGB-00EA0A0-00-00000C00B

Tag: RTU-A

Job Information

Job Name: XXXXXXXXXX
 Job Number: Job #8
 Site Altitude: 0 ft
 Refrigerant: R-410A

Unit Information

Approx. Op./Ship Weights: 1014 lbs / 1014 lbs (±5%)
 Ambient Temperature (DB/WB): 95.0 °F / 65.0 °F
 Coil Filter FV / Qty: 202.5 fpm / 4
 Supply Airflow/ESP: 1800 SCFM / 1.30 in. w.g.
 Outside Airflow: 550 SCFM
 Return Temperature (DB/WB): 75.0 °F / 62.0 °F

Static Pressure

External: 1.30 in. w.g.
 Evaporator: 0.10 in. w.g.
 Filters Clean: 0.13 in. w.g.
 Dirt Allowance: 0.35 in. w.g.
 Reheat Coil:

Economizer: 0.12 in. w.g.
 Heating: 0.02 in. w.g.
 Cabinet: 0.06 in. w.g.
 Total: 2.08 in. w.g.

Cooling Section

	Gross	Net
Total Capacity:	64.1 MBH	61.0 MBH
Sensible Capacity:	57.9 MBH	54.8 MBH
Latent Capacity:	6.2 MBH	
Mixed Air Temp (DB/WB):	81.1 °F	62.9 °F
Entering Air Temp (DB/WB):	81.1 °F	62.9 °F
Lv Air Temp (Coil) (DB/WB):	50.9 °F	49.9 °F
Lv Air Temp (Unit) (DB/WB):	52.5 °F	50.6 °F

Supply Air Fan: 1 x RN150 @ 1.06 BHP Ea.
 SA Fan RPM / Width: 1828 RPM / 3.360 in
 SA Fan FEI: 1.33

Evaporator Coil: 8.5 ft² / 3 Rows / 14 FPI
 Evaporator Face Velocity: 211.6 fpm

Heating Section

Preheat Type: Std (No Preheat)
 Integrated Heat Capacity: 38.3 MBH
 Primary Heat Type: Heat Pump
 Total Capacity: 42.5 MBH
 OA Temp (DB/WB): 20.0 °F / 19.0 °F
 RA Temp (DB/WB): 75.0 °F / 62.0 °F
 Entering Air Temp (DB/WB): 58.2 °F / 51.8 °F
 Leaving Air Temp (DB/WB): 77.3 °F / 59.5 °F
 Input (Emergency/Aux): 20.0 kW / 20.0 kW

Fan Temp Rise: 1.5 °F
 Auxiliary Heating Type: Electric Heat
 Heating Airflow: 1800 SCFM
 Total Capacity: 68.2 MBH
 Entering Air Temp (DB/WB): 77.3 °F / 59.5 °F
 Leaving Air Temp (DB/WB): 112.0 °F / 70.8 °F
 Electric Heat FLA: 24

Rating Information

Application EER @ Op. Conditions: 10.1 BTU/h-W
 Application COP @ Op. Conditions: 2.63 W/W

Electrical Data

Circuit 1

Rating: 460V/3Ø/60Hz
 Unit FLA: 38
 SCCR: 5 KAIC

Minimum Circuit Amp: 46
 Maximum Overcurrent: 50

	Qty	HP	VAC	Phase	RPM	FLA	RLA
Compressor 1:	1		460	3			8.5
Condenser Fan:	1	0.33	460	1	1100	1.6	
Supply Fan:	1	2.00	460	3	1760	3.4	

Cabinet Sound Power Levels*

Octave Bands:	63	125	250	500	1000	2000	4000	8000
Discharge LW (dB):	80	77	80	77	70	68	64	59
Return LW (dB):	75	72	68	63	59	54	42	34

*Sound power levels are given for informational purposes only. The sound levels are not guaranteed.



Unit Rating

2425 South Yukon Ave • Tulsa, OK 74107 • Ph: (918) 583-2266
Ecat Version: 345.0

1A 1B 1C 1D 2 3 4 5A 5B 5C 6A 6B 6C 7 8 9 10 11 12 13 14A 14B 15 16 17 18 19 20 21 22 23

RN-006-3-0-G60C-12A:A000-CLB-DBD-AGB-00EA0A0-00-00000C00B

Job Information

Job Name: [REDACTED]
OA CFM: 550

Job Number: [REDACTED] Job #8
SA CFM: [REDACTED]

Performance Data Table

Outside Air		Mixed Air		Leaving Air		Heat Pump Capacity	Heat Pump Integrated Capacity	Heat Wheel Heating Capacity	Heating COP
DB °F	WB °F	DB °F	WB °F	DB °F	WB °F	MBH	MBH	MBH	W/W
62.0	56.2	71.0	60.3	110.5	72.9	77.3	77.3		3.79
57.0	51.6	69.5	59.0	105.9	71.0	71.5	71.5		3.68
52.0	47.1	68.0	57.9	101.7	69.3	66.3	66.3		3.57
47.0	42.6	66.4	56.8	97.4	67.6	61.1	61.1		3.45
42.0	38.0	64.9	55.7	93.8	66.1	57.2	57.2		3.34
37.0	33.5	63.4	54.8	86.4	63.3	53.2	45.7		2.80
32.0	28.8	61.9	53.8	83.6	62.1	49.5	43.3		2.75
27.0	24.3	60.3	52.9	80.9	60.9	46.2	40.9		2.69
22.0	19.7	58.8	52.0	78.1	59.7	43.0	38.6		2.63
17.0	15.0	57.3	51.1	75.5	58.5	40.1	36.5		2.56
12.0	10.4	55.8	50.3	72.8	57.3	37.4	34.3		2.49
7.0	5.7	54.2	49.5	70.1	56.1	34.8	32.0		2.40
2.0	0.1	52.7	48.6	*	*	*	*		*

*Invalid operation point - Compressor operating outside of operating envelope



15" STAR Plenum

2425 South Yukon Ave • Tulsa, OK 74107 • Ph: (918) 583-2266
Ecat Version: 345.0

JOB INFORMATION:

Job Name: [REDACTED]
Job Tag: RTU-A
Date: 3/18/2024 12:00:00 AM

WHEEL SPECIFICATION:

Max RPM: 2200
Diameter x Qty: 15 in. x 1
CFM: 1800
Inertia: 3WR²

OPERATING CONDITIONS

Air Flow: 1800
Fan Energy Index (FEI): 1.33
Static Pressure: 2.08 in. Wg
Relief Dampers DP: 0 in. Wg
TSP: 2.08 in. Wg
Site Altitude: 0 ft
TSP @ Sea Level: 2.08 in. Wg

MOTOR SELECTION

Rated HP / Bypass: 2 x 1 / No
Frame Size: 145T
Nominal RPM: 1760
VAC/PH/HZ: 460V/3Ø/60Hz
Enclosure Type: ODP
Max Inertial Load: 0 WR²

FAN PERFORMANCE:

RPM: 1828
BHP: 1.06
Efficiency: 55.68%
Max Duct SP with Blocked Airway: 0 in. Wg @ 1828 RPM

FAN SOUND POWER (Inlet/Outlet)

Octave Band:	(Re 10 ⁻¹² watts)							
	1	2	3	4	5	6	7	8
	80	77	80	79	73	71	68	63
	80	77	80	79	73	71	68	63

SOUND POWER A-Weighted: 63 dB

Max Duct SP with Blocked Airway:

Supply Fan Model: RN150 @ 1828 RPM and 100% Width
Design Conditions: 1800 CFM @ 2.08 in. w.g. SP

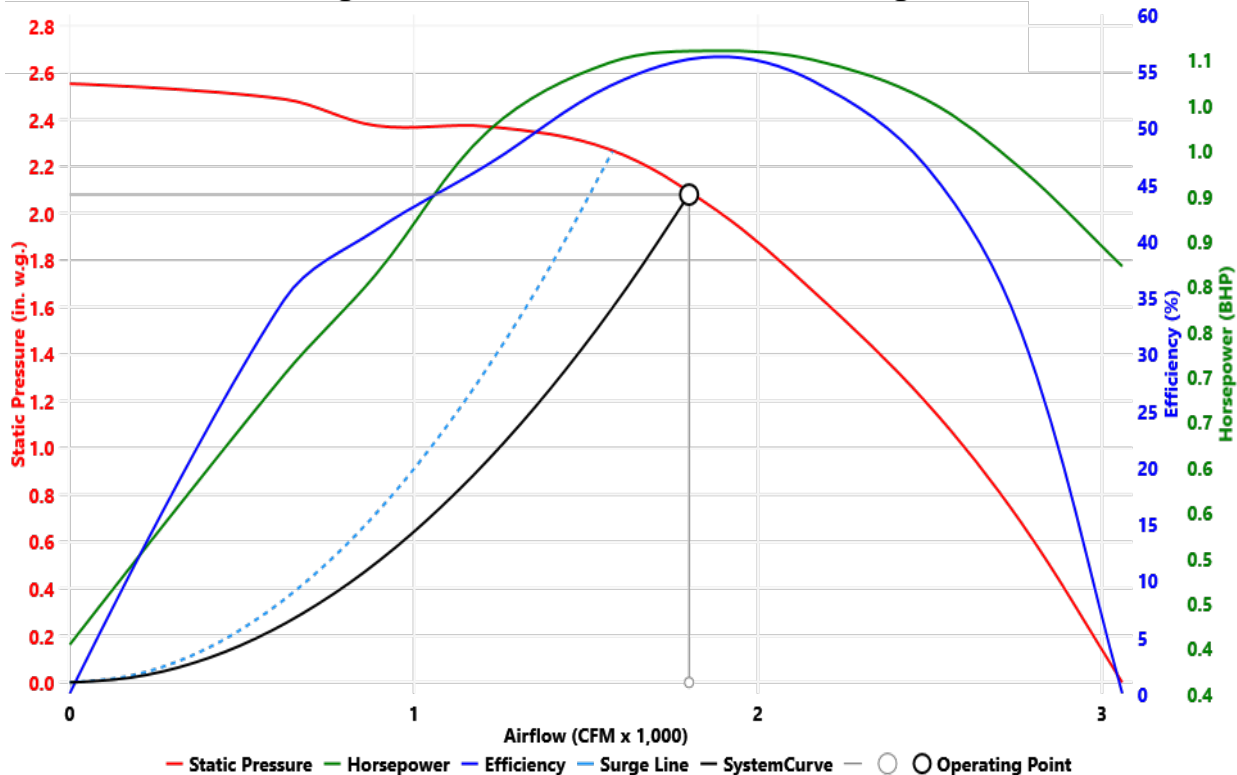



Unit Submittal

2425 South Yukon Ave • Tulsa, OK 74107 • Ph: (918) 583-2266
Ecat Version: 345.0

1A 1B 1C 1D 2 3 4 5A 5B 5C 6A 6B 6C 7 8 9 10 11 12 13 14A 14B 15 16 17 18 19 20 21 22 23

RN-006-3-0-G60C-12A:A000-CLB-DBD-AGB-00EA0A0-00-00000C00B

Tag: RTU-A

Job Name: XXXXXXXXXX
Job Number: Job #8

Unit Worksheet For:
Unit Worksheet Date: 3/18/2024

	Base Option	Description
RN	Generation	Rooftop - Ninth Generation
006	Unit Size	Six
3	Voltage	460V/3φ/60Hz
0	Interior Protection	Standard
G	Refrigerant Style	R-410A Two-Step Compressor - High Efficiency
6	Unit Configuration	Alpha Class - Air-Source Heat Pump
0	Coil Coating	Standard
C	Cooling/Heat Pump Staging	2 Stage Heat Pump + 1 Stage Auxiliary Heat
1	Heating Type	Electric Heat
2	Heating Designation	Heat 2 - 20 kW
A	Heating Staging	Modulating/SCR Electric - 0-10V Control Signal

	Feature Option	Description
A	F1A. RA/OA Section	Economizer
0	F1B. RA/EA Blower Configuration	Standard - None
0	F1C. RA/EA Blower	Standard - None
0	F1D. RA/EA Blower Motor	Standard - None
C	F2. OA Control	Fully Modulating Actuator - Sensible Limit
L	F3. Heat Options	20 kW - Auxiliary Heating Capacity
B	F4. Maintenance Options	115V Convenience Outlet - Factory Wired
D	F5A. SA Blower Configuration	1 Blower + Premium Efficiency Motor + 1 VFD
B	F5B. SA Blower	15" Direct Drive Backward Curved Plenum
D	F5C. SA Motor	2.0 hp - 1760 rpm
A	F6A. Pre Filter Type	2" Pleated Pre Filter - 30% Eff
G	F6B. Unit Filter Type	4" Pleated - 85% Eff - MERV 13
B	F6C. Filter Options	Magnehelic Gauge
0	F7. Refrigeration Control	Standard - Fixed 55°F Comp. Cooling Lock Out + Adjustable Comp. Heating Lock Out
0	F8. Refrigeration Options	Standard
E	F9. Refrigeration Accessories	ECM Condenser Fan - Head Pressure Control
A	F10. Power Options	Non-fused Disconnect Power Switch - 100 Amps
0	F11. Safety Options	Standard
A	F12. Controls	Low Limit Controls
0	F13. Special Controls	Terminal Block for Thermostat Control
0	F14A. Outside Air Configuration	Standard - None
0	F14B. Preheat Sizing	Standard - None
0	F15. Glycol Percent	Water or No WSHP
0	F16. Interior Cabinet Options	Standard - Double Wall + R-13 Foam Insulation + Stainless Steel Drain Pan
0	F17. Exterior Cabinet Options	Standard
0	F18. Electrical Rating	Standard - 5 KAIC
0	F19. Code Options	Standard - ETL U.S.A. Listing
C	F20. Crating	Shrink Wrap
0	F21. Water-Cooled Cond.	Standard - None
0	F22. Control Vendors	Standard
B	F23. Type	Standard - Includes AAON Gray Paint



Terminals

2425 South Yukon Ave • Tulsa, OK 74107 • Ph: (918) 583-2266
Ecat Version: 345.0

1A 1B 1C 1D 2 3 4 5A 5B 5C 6A 6B 6C 7 8 9 10 11 12 13 14A 14B 15 16 17 18 19 20 21 22 23

RN-006-3-0-G60C-12A:A000-CLB-DBD-AGB-00EA0A0-00-00000C00B

Tag: RTU-A

Job Name:



For:

Job Number:

Job #8

Date:

March 18, 2024

Terminals Available/Required for Controlling the Unit

Terminals	Description
[R]	24VAC Control Voltage
[C]	Common
[G]	Supply Fan Enable
[Y1]	Cooling Stage 1 Enable/ Heat Pump - Heating Stage 1 Enable
[O]	Reversing Valve (Cooling) Enable
[W1]	Aux Heat Stage 1 Enable
[+] & [-]	SCR Control Signal (0-10VDC)
[A1] & [A2]	Economizer Enable
[S1-] & [S2+]	Supply Fan 1 - w/ 1 VFD: Signal (0-10VDC)
	VFD frequency reference signal control point must handle a rated 20k ohm input impedance.

RN SERIES

A - CABINET ECONOMIZER ~ 6-10 TON

CLEARANCES	
LOCATION	• UNIT SIZE • 6 - 10 TON
OUTSIDE AIR (BACK)	36*
CONTROLS SIDE (FRONT)	48
LEFT SIDE	6
RIGHT SIDE	48
TOP	UNOBSTRUCTED

*CLEARANCE IS MEASURED FROM THE END OF THE OUTSIDE AIR RAIN HOOD

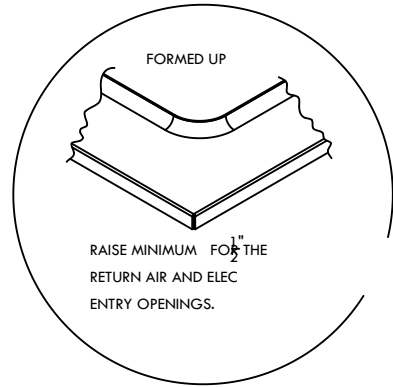
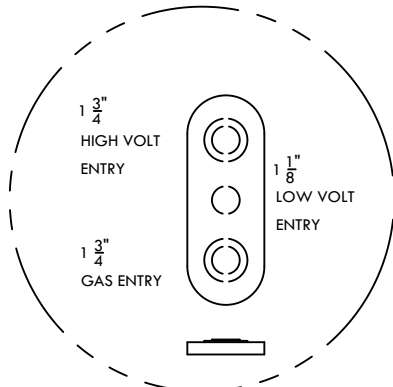

DETAIL A

DETAIL B

NOTE: THE RNA UNIT IS NOT COMPATIBLE WITH PREVIOUS GENERATIONS OF AON CURBS. AN ADAPTER CURB IS AVAILABLE IN ECAT.

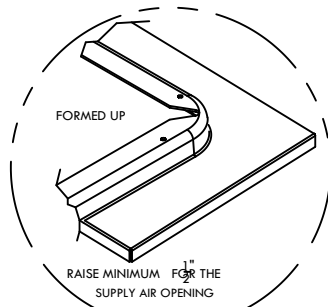

DETAIL C

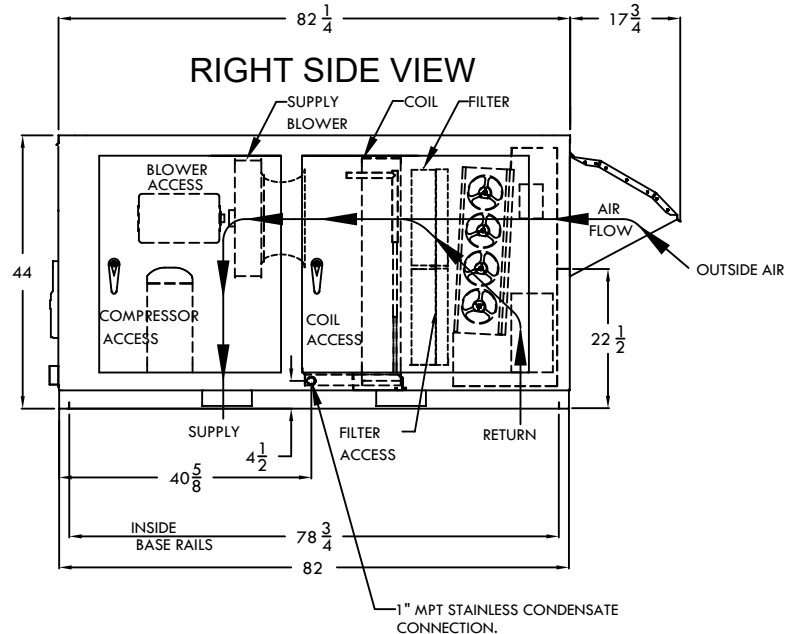
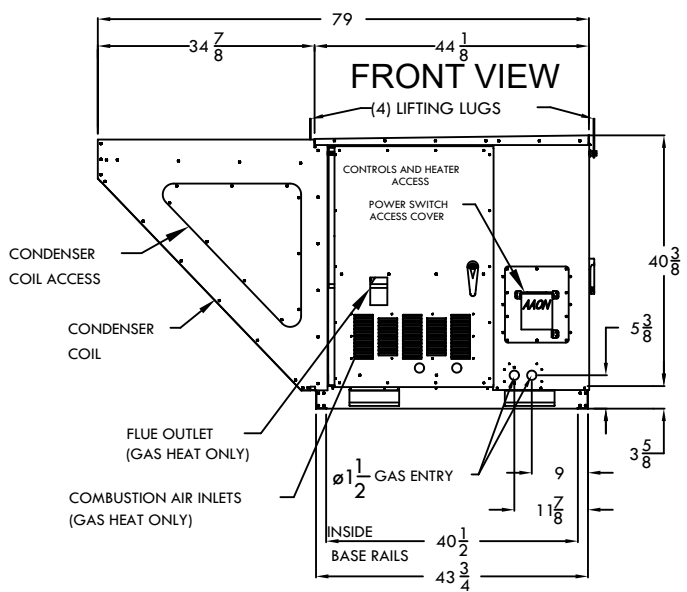
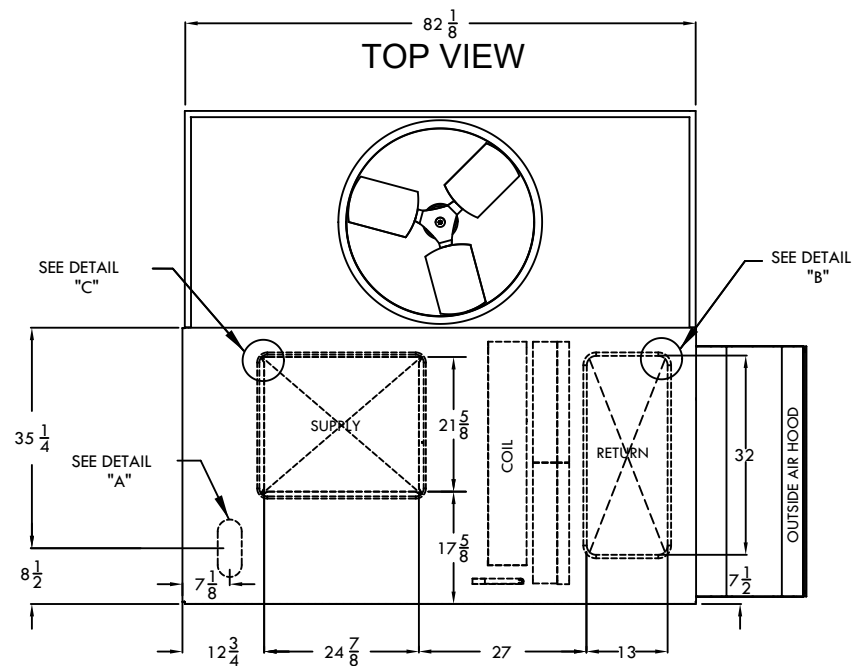

RNA CABINET AIR COOLED CONDENSING UNIT



RN-006-3-0-G60C-12A:A000-CLB-DBD-AGB-00EA0A0-00-00000C00B

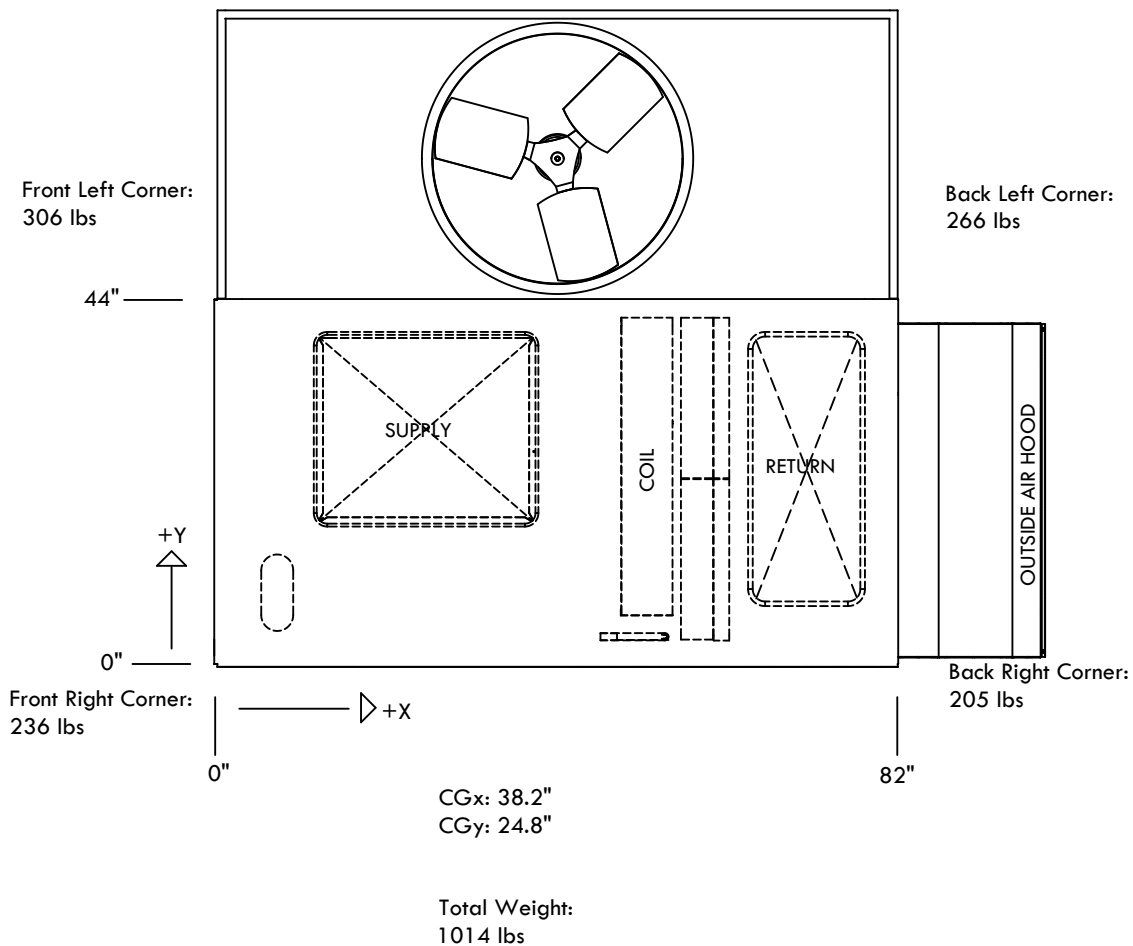

Disclaimer:
This weight estimate does not account for any SPAs.



COOK



MARK: RES ELEC RF
PROJECT: DC 10MW
DATE: 09/27/2024

HXEL

Hooded Exhaust Ventilator Low-Pressure Steel Propeller Roof Mounted/Belt Drive

STANDARD CONSTRUCTION FEATURES:

X-stream steel propeller - Spun steel Venturi/curb cap - Lorenized steel lower housing - Galvanized steel hood - Birdscreen - Heavy duty steel power assembly - Welded curb cap corners - Adjustable pitch drives through 5 hp motor - Regreasable bearings in cast housing rated at 200,000 hours average life - Propellers are statically and dynamically balanced - Corrosion resistant fasteners - Oil and heat resistant, static conducting belts - All fans factory adjusted to specified RPM.

NOTE: Sizes 42-60 require field assembly of hood.

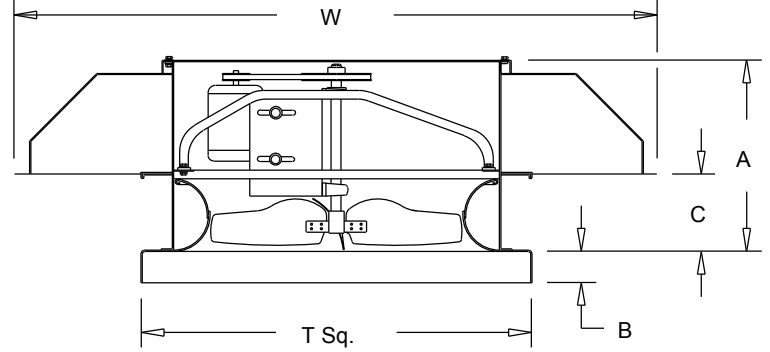

Performance (*Bhp includes 8% drive loss)

Qty	Catalog Number	Flow (CFM)	SP (inwg)	Fan RPM	Power* (HP)	FEG	FEI
1	36HXEL11B	15000	.250	685	2.26	60	1.24

Altitude (ft): 0 Temperature (F): 70

Motor Information

HP	RPM	Volts/Ph/Hz	Enclosure	FLA	Mounted	VFD Rated
5	1725	460/3/60	ODP -PE	7.6	Yes	Yes

NEMA Premium® efficiency motor per MG-1 (2014) Table 12-12
FLA based on NEC (2017) Table 430.250

Sound Data Inlet Sound Power by Octave Band

1	2	3	4	5	6	7	8	LwA	dBA	Sones
85	88	84	78	74	70	68	63	81	70	19.3

- Distance from Sound source 5 ft

Accessories:

- Premium Efficiency Motor (Min. 89.5%)
- DRIVES (1.5 SF) @ 685 RPM
- DISCONNECT NEMA 3
- ANTICONDENSATE COAT
- LIFTING LUGS
- EXTENDED LUBE LINES
- SPARE BELT SET

Dimensions (inches)

A	33
B	3
C	10
L x W	80 x 80
T Sq.	48
Base Ga.	14
Hood Ga.	18
Roof Open.Sq.*	43-1/2

NOTE: Accessories may affect dimensions shown.

Weight(lb)***	Shipping	951	Unit	688
---------------	----------	-----	------	-----

*ROOF OPENING SIZE FOR CURBS SUPPLIED BY COOK ONLY.
***Includes fan, motor & accessories.

Fan Curve

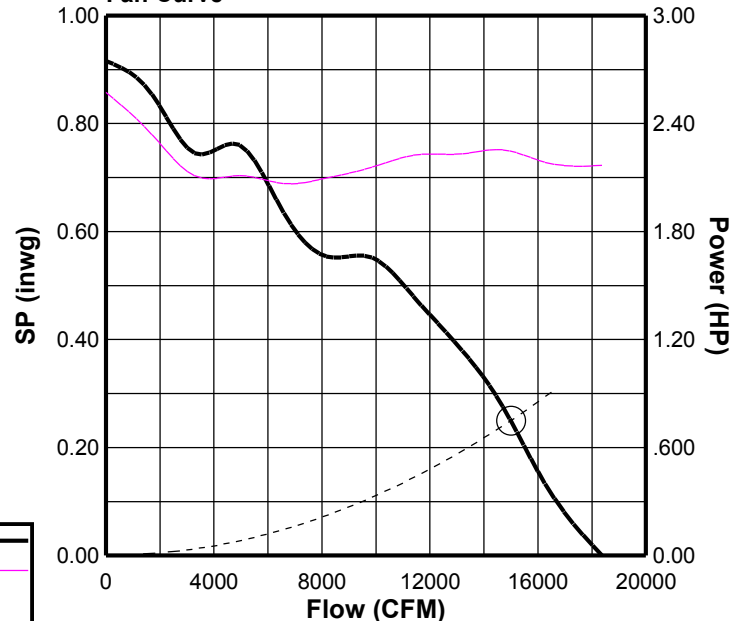

Fan Curve Legend

CFM vs SP	—
CFM vs HP	—
Point of Operation	○
System Curve	- - -



COOK



MARK: RES ELEC RF
PROJECT: DC 10MW
DATE: 09/27/2024

HXEL

Performance (*Bhp includes 8% drive loss)

Catalog Number	Flow (CFM)	SP (inwg)	Fan RPM	Power* (HP)	FEG	FEI	OVEL (FPM)	TSPD (FPM)	SE	Temp (°F)	ALT (ft)
36HXEL11B	15000	.250	685	2.26	60	1.24	2038	6456	28%	70	0

Sound Data Inlet Sound Power by Octave Band

1	2	3	4	5	6	7	8	LwA	dBA	Sones
85	88	84	78	74	70	68	63	81	70	19.3

Motor Information

HP	RPM	Volts/Ph/Hz	Enclosure	FLA	Mounted	VFD Rated
5	1725	460/3/60	ODP -PE	7.6	Yes	Yes

FLA based on NEC (2017) Table 430.250

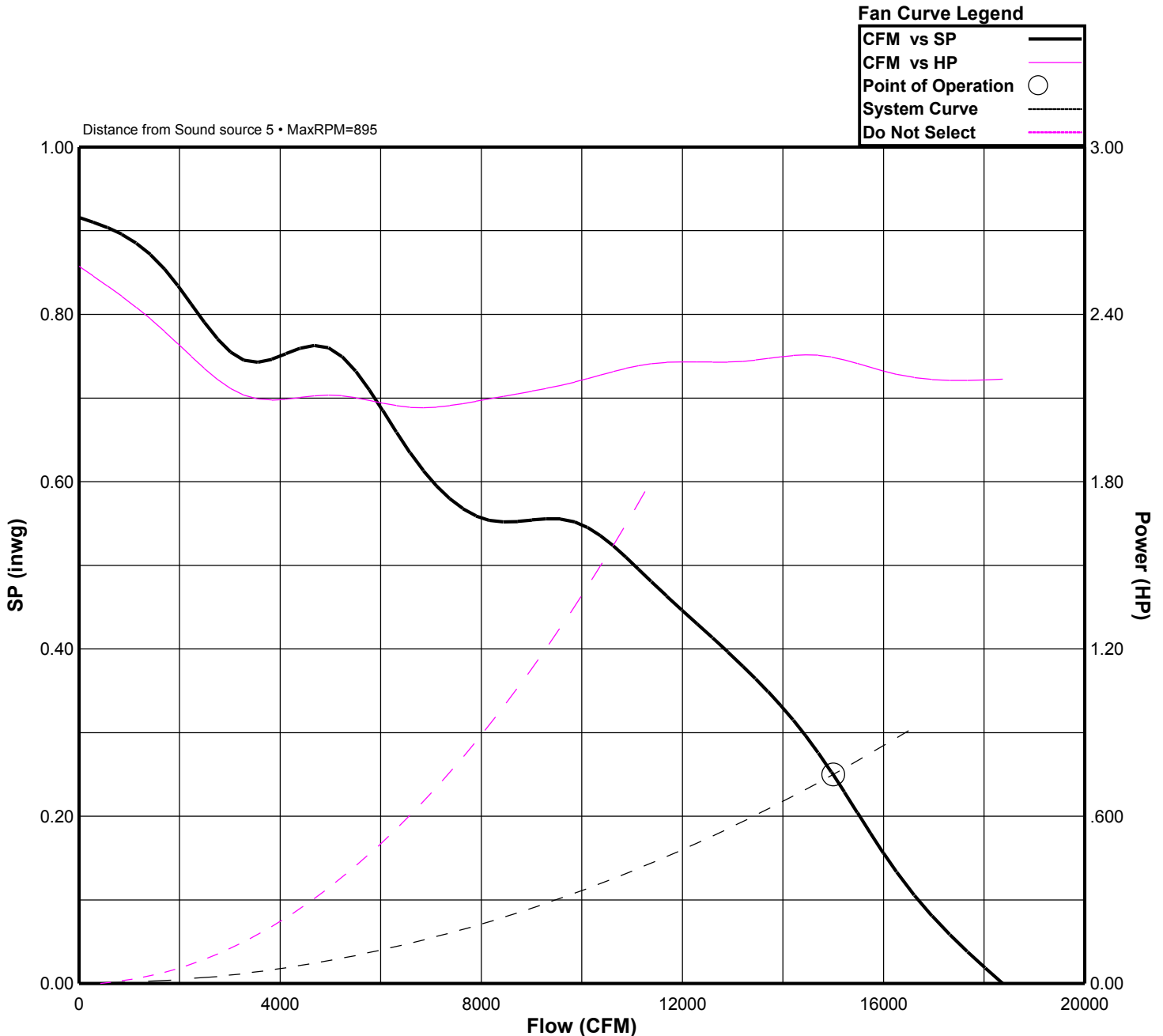



COOK

HXEL

MARK: RES ELEC RF
PROJECT: DC 10MW
DATE: 09/27/2024

AMCA License Information



Loren Cook Company certifies that the 36HXEL11B shown herein is licensed to bear the AMCA Seal. The ratings shown are based on tests and procedures performed in accordance with AMCA Publication 211 and AMCA Publication 311 and comply with the requirements of the AMCA Certified Ratings Program.

Performance certified is for installation type A: free inlet, free outlet. Power rating (BHP/kW) does not include transmission losses. Performance ratings do not include the effects of appurtenances (accessories). The sound ratings shown are loudness values in hemispherical sones at 5 ft. in a hemispherical free field calculated per AMCA Standard 301. Values shown are for Installation type A: free inlet hemispherical sone levels. The AMCA International licensed air and/or sound performance data has been modified for installation, appurtenances or accessories, etc. not included in the certified data. The modified performance is not AMCA licensed but is provided to aid in selection and applications of the product.



The sound power level ratings shown are in decibels, referred to 10(-12) watts calculated per AMCA Standard 301. Values shown are for inlet Lwi and LwiA sound power levels for installation type A: free inlet, free outlet. Ratings do not include the effects of duct end correction. The A-weighted sound ratings shown have been calculated per AMCA Standard 301. The dBA levels shown have been calculated for a distance of 5 ft in a hemispherical free field. The AMCA Certified Ratings Seal applies to free air sone ratings only. Octave Band, LwA and dBA levels are not AMCA International licensed.



COOK

MARK: RES ELEC RF
PROJECT: DC 10MW
DATE: 09/27/2024

Limited Warranty

Loren Cook Company warrants that your Loren Cook fan was manufactured free of defects in materials and workmanship, to the extent stated herein. For a period of one (1) year after date of shipment, we will replace any parts found to be defective without charge, except for shipping costs which will be paid by you.

This warranty is granted only to the original purchaser placing the fan in service.

This warranty is void if the fan or any part thereof has been altered or modified from its original design or has been abused, misused, damaged or is in worn condition or if the fan has been used other than for the uses described in the company manual. This warranty does not cover defects resulting from normal wear and tear.

To make a warranty claim, notify Loren Cook Company, General Offices, 2015 East Dale Street, Springfield, Missouri 65803-4637, explaining in writing, in detail, your complaint and referring to the specific model and serial numbers of your fan. Upon receipt by Loren Cook Company of your written complaint, you will be notified, within thirty (30) days of our receipt of your complaint, in writing, as to the manner in which your claim will be handled. If you are entitled to warranty relief, a warranty adjustment will be completed within sixty (60) business days of the receipt of your written complaint by Loren Cook Company.

This warranty gives only the original purchaser placing the fan in service specifically the right. You may have other legal rights which vary from state to state.

For fans provided with motors, the motor manufacturer warrants motors for a designated period stated in the manufacturer's warranty. Warranty periods vary from manufacturer to manufacturer. Should motors furnished by Loren Cook Company prove defective during the designated period, they should be returned to the nearest authorized motor service station. Loren Cook Company will not be responsible for any removal or installation costs.